

---

**TECHNICAL MANUAL**

**DIRECT SUPPORT AND GENERAL SUPPORT  
MAINTENANCE MANUAL**

**ELECTRONIC EQUIPMENT  
CONFIGURATION ARMY MODEL  
OH-58A HELICOPTER  
(NSN 1520-00-169-7137)**

---

**HEADQUARTERS, DEPARTMENT OF THE ARMY  
31 DECEMBER 1975**

## **WARNING**

### **DANGEROUS VOLTAGES EXIST IN THIS CONFIGURATION**

Be careful when working around the 115-volt ac input of the inverter. The 115 volt ac is present throughout the gyromatic compass facility wiring.

### **CAUTION**

To avoid transistor and integrated circuit damage, make certain that all electronic equipment function and source power switches are in the OFF position before changing cable connections. Check the source voltage and polarity before making connections. **TRANSISTORS AND INTEGRATED CIRCUITS MAY BE PERMANENTLY DAMAGED BY IMPROPER VOLTAGE OR POLARITY.**

### **CAUTION**

Do not stand in front of the AN/APX-72 antenna when it is transmitting.

## **WARNING**

### **DANGEROUS CHEMICALS ARE USED IN NICKEL-CADIUM BATTERIES**

The electrolyte used in nickel-cadium batteries contains potassium hydroxide (KOH), which is a caustic agent. Serious and deep burns of body tissue will result if the electrolyte comes in contact with the eyes or any part of the body. Use rubber gloves, rubber apron, and protective goggles when handling the electrolyte. If accidental contact with the electrolyte is made, use **ONLY** clean water and immediately (seconds count) flush contaminated areas. Continue flushing with large quantities of clean water for at least 15 minutes. Seek medical attention without delay.

HEADQUARTERS  
DEPARTMENT OF THE ARMY  
WASHINGTON, DC 24 August 1978

CHANGE }  
No. 2 }

**Direct Support and General Support Maintenance Manual  
ELECTRONIC EQUIPMENT CONFIGURATION ARMY MODEL OH-58A HELICOPTER  
(NSN 1520-00-169-7137)**

TM 11-1520-228-34, 31 December 1975, is changed as follows

1. New or changed material is indicated by a vertical bar in the margin.
2. Added or revised illustrations are indicated by a vertical bar adjacent to the figure number.
3. Remove and insert pages as indicated in the page list below

<b>Remove</b>	<b>Insert</b>
i and ii .....	i and ii
1-1 thru 1-4 .....	1-1 thru 1-4
2-1 thru 2-4 .....	2-1 thru 2-4
2-13 and 2-14 .....	2-13 and 2-14
3-6 and 3-6 .....	3-5 and 3-6 and 3-6.1
None .....	3.25/(3 -26 blank)
A-1 .....	A-1 and A-2
Index 1 and Index 2 .....	Index 1 and Index 2
None .....	Insert sample DA Form 2028-2 (back of manual )
None .....	FO-10

4. File this change sheet in the front of the manual for reference purposes.

By Order of the Secretary of the Army:

**BERNARD W. ROGERS**  
*General United States Army*  
*Chief of Staff*

Official:

**J. C. PENNINGTON**  
*Brigadier General, United States Army*  
*The Adjutant General*

**DISTRIBUTION**

To be distributed in accordance with DA Form 12-31, Section VI, Direct and General Support Maintenance requirements for OH-58 aircraft.

CHANGE }  
No. 1 }

HEADQUARTERS  
DEPARTMENT OF THE ARMY  
WASHINGTON, DC, 18 April 1977

Direct Support and General Support  
Maintenance Manual  
ELECTRONICS EQUIPMENT CONFIGURATION  
ARMY MODEL OH-58A HELICOPTER  
(NSN 1520-00-169-7137)

TM 11-5820-228-34, 31 December 1975, is changed as follows:

1. New or changed material is indicated by a vertical bar in the margin.
2. Remove and insert pages as indicated in the page list below:

Remove  
i and ii  
3-21 and 3-22

Insert  
i and ii  
3-21 through 3-22.1

3. File this change sheet in the front of the publication for reference purposes.

By Order of the Secretary of the Army:

BERNARD W. ROGERS  
General, United States Army  
Chief of Staff

Official:

PAUL T. SMITH  
Major General, United States Army  
The Adjutant General

Distribution:

To be distributed in accordance with DA Form 12-31, Direct and General Support maintenance requirements for OH-58 aircraft.

Technical Manual }  
No. 11-1520-228-34 }

HEADQUARTERS  
DEPARTMENT OF THE ARMY  
Washington DC 31 December 1975

DIRECT SUPPORT AND GENERAL SUPPORT  
MAINTENANCE MANUAL

**ELECTRONIC EQUIPMENT CONFIGURATION  
ARMY MODEL OH-58A HELICOPTER  
(NSN1520-00-169-7237)**

	Paragraph	Page
CHAPTER 1. INTRODUCTION .....	1-1-1-6	1 - 1 - 1 - 4
2. FUNCTION		
Section II. Configuration Interunit Circuit Analysis .....	2-1-2-16	2 - 1 - 2 - 11
II. Equipment Functional Description .....	2-17-2-21	2 - 13 - 2 - 14
CHAPTER 3. DIRECT SUPPORT MAINTENANCE		
Section I. Maintenance Techniques .....	3-1-3-3	3 - 1 - 3 - 2
II. Configuration Interknit Troubleshooting .....	3-4-3-16	3 - 2 - 3 - 8
III. Electronic Configuration Repairs Alignment .....	3-17-3-24	3 - 8 - 3 - 19
CHAPTER 4. DIRECT SUPPORT TESTING PROCEDURES		
Section I. Introduction .....	4-1, 4-2	4 - 1, 4 - 1
II. Testing.....	4-3-4-8	4 - 1 - 4 - 2
CHAPTER 5. GENERAL SUPPORT MAINTENANCE .....		5 - 1 - 5 - 8
A P P E N D I X.....		A - 1
I N D E X .....		I n d e x - 1

**\*This manual supersedes TM 11-1520-228-34, dated 5 May 1969, including all changes.**

LIST OF ILLUSTRATIONS

Figure	Title	Page
2-1.	Primary Power Application Schematic Diagram . . . . .	2-2
2-2.	VHF Command Facility Interunit, Schematic Diagram. . . . .	2-4
2-3.	VHF Command Facility Interunit, Schematic Diagram Without Audio Threshold System . . . . .	2-5
2-4.	Audio Threshold System (view looking up from right side of helicopter at nose area forward of (behind) instrument panel) . . . . .	2-7
2-5.	Uhf Command Facility (AN/ARC-116) Interunit Schematic Diagram . . . . .	2-8
2-6.	Uhf Command Facility (AN/ARC-116) Interunit Schematic Diagram Without Audio Threshold System . . . . .	2-9
2-7.	Compass Facility Interunit Schematic Diagram . . . . .	2-12
3-1.	OH-58 A Helicopter Equipment Location . . . . .	3-11
3-2.	Gyro Installation . . . . .	3-12
3-3.	Adf Installation . . . . .	3-13
3-4.	Fm Installation. . . . .	3-14
3-5.	Fm Antenna Installation . . . . .	3-15
3-6.	Vhf Installation . . . . .	3-16
3-7.	Uhf-Am Installation. . . . .	3-17
3-8.	[ff Installation. . . . .	3-18
3-9.	Ics Installation . . . . .	3-19
3-10.	Headset Interconnect Installation. . . . .	3-20
3-11.	Tail Boom Communications Installation. . . . .	3-21
312.	Impedance-Matching Network Layout, Component side . . . . .	3-22
3-12.1	Impedance-Matching Network Layout, Foil Side . . . . .	3-22
3-12.2	Impedance-Matching Network, Schematic Diagram . . . . .	3-22.1
3-13.	Capacitor Board A3 Layout. . . . .	3-22.1
3-14.	Proximity Warning Installation. . . . .	3-23
3-15.	Adf Facility Alignment Test Setup. . . . .	3-23
3-16.	Adf Receiver,Cover Removed. . . . .	3-24
3-17	Impedance-Matching Network Test Setup . . . . .	3-24
3 - 1 8	R a d a r   w a r n i n g   c o n f i g u r a t i o n	3 - 2 5
4-1.	Load Bank,Schematic Diagram . . . . .	4-3
4-2.	Load Bank, Panel Layout. . . . .	4-4
4-3.	Inverter Test Setup . . . . .	4-4
4-4.	Transponder Test Set AN/APM-123(V)l . . . . .	4-5
4-5.	Antenna Test Hood Installation MX-4396/APM-123 (V)l. . . . .	4-6
5-1.	ATS Test Setup Audio Section . . . . .	5-2
5-2.	ATS.Audio Output Wave form. . . . .	5-2
5-3.	ATS Test Setup Control Section . . . . .	5-3
5-4.	ATS Schematic Diagram. . . . .	5-5
5-5.	ATS Exploded View . . . . .	5-6
5-6.	ATS Circuit Board Assembly. . . . .	5-7
FO-1.	Color Code for Resistor, Inductors, and Capacitors. . . . .	Located in back of manual.
FO-2.	Liaison Facility Interunit Schematic Diagram . . . . .	Located in back of manual.
FO-3.	Liaison Facility Interunit Schematic Diagram Without Audio Threshold System . . . . .	Located in back of manual.
FO-4.	Automatic Direction Finder Facility Interunit Schematic Diagram . . . . .	Located in back of manual.
FO-5.	Identification Facility Interunit Schematic Diagram . . . . .	Located in back of manual.
FO-6.	Intercom and Audio Facility Interunit Schematic Diagram . . . . .	Located in back of manual.
FO-7.	Intercom and Audio Facility Interunit Schematic Diagram Without Audio Threshold System . . . . .	Located in back of manual.
FO-8.	Uhf Command Facility Interunit Schematic Diagram (AN/ARC-51 BX) . . . . .	Located in back of manual.
FO-9.	Proximity Warning Facility Interunit Schematic Diagram . . . . .	Located in back of manual.
FO-10	Radar Warning System AN/APR-39 Wiring Diagram . . . . .	Located in back of manual.

## CHAPTER 1

### INTRODUCTION

#### 1-1. Scope

a. This manual covers direct support and general support maintenance of the electronic equipment configuration for Army Model OH-58A Helicopter, serial numbers 68-16687 through 68-16986, 69-16080 through 69-16876, 70-15050 through 70-15649, 71-20340 through 71-20476, 71-20879 through 71-20939, 72-21061 and subsequent, and helicopters that have been retrofitted in accordance with MWO 55-1520-228-50-4. This manual includes instructions appropriate to direct and general maintenance personnel for troubleshooting electronic equipment when the equipment is installed in a helicopter. Tools, test equipment, and materials necessary to maintain the helicopter electronic equipment configuration are listed in this manual, which also includes complete maintenance instructions for direct and general support maintenance personnel.

b. Bench maintenance of many of the electronic equipment configuration components is covered in other technical manuals. Pertinent technical manuals for the electronic equipments are listed in appendix A. When servicing the equipments, refer to the pertinent technical manuals for detailed troubleshooting, testing, aligning, and replacing or repairing maintenance parts.

c. Block diagram analysis of the entire electronic configuration and the individual facilities in the electronic configuration is covered in TM 11-1520-228-20. Analysis of the electronic configuration intermit circuits is covered in chapter 2 of this manual. Block diagrams and detailed circuit analysis of electronic equipment components and ancillary electronic equipment not covered in separate technical manuals are covered in chapter 3. For electronic equipment covered by separate technical manuals, refer to the pertinent technical manual (listed in app A) for block diagram and detailed circuit analysis.

d. Throughout this manual, electronic equipment components are referred to by common names. For a list of equipment nomenclature and the assigned common names, refer to TM 11-1520-228-20.

e. Maintenance of Army aircraft is changing to three categories of maintenance. These maintenance categories are Aviation Unit Maintenance (AVUM) Aviation Intermediate Maintenance (AVIM); and Depot Maintenance. AVUM will replace organizational, AVIM will replace direct and general support maintenance. In the interim, as maintenance units are reorganized into three categories of maintenance activities, this publication will be used by personnel for the maintenance of the electronic equipment con-

figuration. The maintenance allocation chart (MAC) is configured to the three-category maintenance concept where the code O represents AWM; the code F represents AVIM and D represents depot maintenance. Those organizations not yet assigned complete AVUM responsibilities should use caution in utilization of this publication. Whatever maintenance is performed must consider available skills, tools, test equipment, and time required to perform the maintenance.

#### NOTE

For applicable forms and records, refer to paragraph 1-3, TM 11-1520-228-20.

#### 1-2. Indexes of Publications

a. DA Pam 310-4. Refer to DA Pam 310-4 to determine if there are new editions, changes, or additional publications pertaining to the electronic equipment configuration for Helicopter, Observation OH-58A.

b. DA Pam 310-7. Refer to DA Pam 310-7 to determine if there are modification work orders (MWO'S) pertaining to the equipment.

#### 1-3. Reporting of Errors

The reporting of errors, omissions, and recommendations for improving this manual by the individual user is encouraged. Reports should be submitted on DA Form 2028 (Recommended Changes to Publications and Blank Forms) or DA Form 2028-2 located in the back of the manual, and forwarded direct to Commander, US Army Communications and Electronics Materiel Readiness Command, ATTN DRSEL-MA-Q, Fort Monmouth, NJ 07703. To use the form in the back of the manual, cut it out, fill it out as shown on the sample, fold it where shown, and drop it in the mail. A reply will be furnished direct to you.

#### 1-3.1. Reporting Equipment Improvement Recommendations (EIR)

EIR's will be prepared using DA Form 2407, Maintenance Request. Instructions for preparing EIR's are provided in TM 38-750, the Army Maintenance Management System. EIR's should be mailed direct to Commander, US Army Communications and Electronics Materiel Readiness Command, ATTN DRSEL-MA-Q, Fort Monmouth, NJ 07703. A reply will be furnished direct to you.

#### 1-4. Reference Designations

a. General Reference designations consist of groups of letters and numbers that identify units, assemblies, subassemblies, and parts. Each reference designation used throughout this manual on applicable illustrations and in the text to identify a particular item is also used in the parts list to identify the same item. Some of

the electronic equipment within the overall configuration has reference designations assigned to items according to the unit numbering system, and some equipments use the block numbering system. For the reference designation system and grouping of items within a particular electronic equipment, refer to the applicable technical manuals for that equipment. For those equipments that do not have separate technical manuals refer to c below. For reference designations assigned to items of the overall electronic equipment configuration and the particular facility with which the items are associated, refer to the chart in b below.

b. Electronic Configuration. The following chart lists the facilities, the applicable electronic equipments, and the reference designation grouping of all installation hardware items and parts associated with the facilities.

Facility	Equipment	Grouping
Intercommunication and Audio <sup>a</sup>	Control, Communication System C-6533/ARC (three installed) and associated installation items.	1-99
	Network, avionics, electrical, and armament and associated installation items.	1-99
Liaison <sup>ab</sup>	Radio Set AN/ARC-114 and associated installation items.	101-199
	Antenna, Fm Homing 206-075-523-1 and 206-075-523-2 and associated installation items.	101-199
	Antenna, Fm No. 2 and associated installation items.	101-199
Vhf command I	Radio Set AN/ARC-115 and associated items.	201-299
Uhf command <sup>d</sup>	Radio Set AN/ARC-51BX and associated installation items.	301-399
Automatic direction finder <sup>a</sup>	Direction Finder Set AN/ARN-89.	401-499
	Receiver, Radio R-1496/ARN-89 and associated installation items.	401-499
	Control, Radio Set C-7392/ARN-89 and associated installation items.	401-499
	Amplifier, Impedance. Matching AM-48591/ARN-89 and associated installation items.	401-499
	Antenna AS-2108/ARN-89 and associated installation items.	401-499
Compass <sup>d</sup>	Antenna 206-032-310	401-499
	Gyromagnetic Compass Set AN/ASN-43.	501-599
	Transmitter, Induction Compass T-611/ASN and associated installation items.	501-599
	Compensator, Magnetic Flux CN-405/ASN and associated installation items.	501-599
	Gyro, Directional CN-998/	501-599

Facility	Equipment	Grouping
Identification <sup>a</sup>	ASN-43 and associated installation items.	
	Heading-Radio Bearing Indicator ID-1351/A and associated installation items.	501-599
	Switch, compass slaving and associated installation items.	S101
	Inverter, Static 8062-2 and associated installation items.	501-599
	Transponder Set AN/APX-72.	601-699
	Receiver-Transmitter, Radio RT-859/APX-72 and associated installation items.	601-699
	Control, Transponder C-6280 (P)/APX-72 and associated installation items.	601-699
	Computer, Transponder KIT- 1A/TSEC and associated installation items.	601-699
	Antenna AT-8641APX-72 and associated installation items.	601-699
	Test Set TS-1843A/APX-72 and associated installation items.	601-699
Voice security <sup>ac</sup>	Light, code hold and associated installation items.	DS51
	Switch, code hold and associated installation items.	S102
	Computer, Voice Security TSEC/KY-28 and associated installation items.	701-799
	Control Indicator, Voice Security C-8157/ARC and associated installation items.	701-799
Battery	Light, remote cipher and associated installation items.	701-799
	Battery, storage and associated installation items.	801-899
Antenna	Antenna, vhf/fro 206-075-518-1 and associated installation items.	901-999
	Antenna, uhf 206-075-551-1 and associated installation items.	1001-1999
Proximity warning <sup>e</sup>	Proximity Warning YG-1054	1101-1199
	Receiver, Transponder and associated installation items,	1101-1199
Radar warning	Antenna and associated installation items.	1101-1199
	Radar Warning AN/APR-39	1201-129
	Control Panel, Radar Warning C-9326()/APR-39	1201-1299
	Indicator, Radar Warning ID-1150()/APR-39	1201-1299
	Comparator, Radar Warning CM-440()/APR-39	1201-1299
	Dual Receiver, Radar Warning R-1838()/APR-39	1201-1299
	Antenna, Blade AS-2890 ( )/APR-39	1201-1299
Antenna, Spiral AS-2891	1201-1299	



Facility	Equipment	Grouping
	(J)APR-39	
	Antenna, Spiral AS-2892	1201-1299
	(J)/APR-39	

1 Refer to TM 11-1520-228-20 for a breakdown listing of installation items.

One installed complete provisions included for a second.

Complete provisions only.

Provisions are supplied for Radio Set AN/ARC-116 and associated installation items which use the same grouping as Radio Set AN/ARC-51BX.

Provisions for Proximity Warning Facility YG-1054 are accomplished at designated training commands by the application of MWO 55-1520-228-30/22.

When MWO 55-1520-228-50-4 has been accomplished.

c. Electronic Equipment The following lists the electronic equipment used in the electronic configuration that is not covered in separate technical manuals, and the applicable reference designation grouping of each electronic equipment.

(1) Inverter, Static 8062-3.

(2) Network, Avionics, Electrical Armament 206-075-483.

(3) Antenna 206-075-518 vhf/fro.

(4) Antenna 206-075-543 No. 2 Fm.

(5) Antenna Fm Homing 206-075-523-1 and 206-075-523-2.

(6) Antenna 206-075-551 uhf.

(7) Audio Threshold Device 206-075-597.

1-5. Proximity Warning Facility Installation Proximity Warning Facility YG-1054 (PWS) is primarily intended for use by training commands in high density aircraft areas to avoid mid-air collisions. The PWS installation is accomplished by applying MWO 55-1520-228-30/22 and change 1 to that MWO, which achieves dual fm communication capability to all aircraft based on Department of Army allocation. The proximity warning facility can be applied to all aircraft.

**1-5.1. Radar Warning System Installation**

Radar Warning System, AN/APR-39, is installed on helicopters having MWO 55-1520-228-50-4 accomplished. This system provides both visual and audible warning when a high threat radar environment is encountered. It can sort out, identify and display threat radar signals.

**1-6. Use of Term Hertz**

The National Bureau of Standards has officially adopted the term hertz (Hz) to replace cycles per second. The chart below provides the equivalents of the unit/quantity terms and the list of approved abbreviations that will be used throughout the manual.

Unit quantity	old term	old abbreviation	New term	New abbreviation
Frequency	Cycles per second	Cps	hertz	Hz
10 <sup>3</sup> cycles per second	Kilocycles per second	Kc	kilohertz	kHz
10 <sup>6</sup> cycles per second	Megacycles per second	Mc	megahertz	MHz
10 <sup>9</sup> cycles per second	Gigacycles per second	Gc	gigahertz	GHz

## CHAPTER 2

## FUNCTIONING

## Section 1. CONFIGURATION INTERUNIT CIRCUIT ANALYSIS

## 2-1. Introduction to Functioning Discussions

The purpose, operation, and interoperation of the various electronic and electrical circuits are explained in this chapter and also in the respective equipment technical manuals (app A). Familiarity with the electronic equipment configuration and the individual electronic equipments is valuable in rapidly and effectively troubleshooting the electronic equipment configuration and the individual electronic equipment.

## 2-2. Primary Power Application

(fig. 2-1)

a. General. Dc power distribution within the aircraft provides for a split-bus system to supply the electronic equipment. Power for equipment considered necessary for flight safety is supplied by the essential bus through circuit breakers. The nonessential bus supplies dc power through circuit breakers to the inverter and the remainder of the electronic equipment. The following list of circuit breakers will demonstrate grouping for each bus.

## (1) 28 vdc essential bus-circuit breakers:

IFF TEST SET (5 amp)  
 IFF (10 amp)  
 ADF (5 amp)  
 UHF (15 amp) AN/ARC-51BX  
 UHF (5 amp) AN/ARC-116  
 ICS (5 amp)  
 ADF (5 amp)  
 UHF (5 amp)  
 ICS (5 amp)  
 PROX WARN (2 amp)

RDR WRN (5 amp)

**NOTE**

The proximity warning facility is installed only at designated training commands and provisions are made by applying MWO 55-1520-228-30/22, C1, which achieves dual fm communications capability.

## (2) 28 vdc nonessential bus-circuit breakers:

SPEECH SECURITY (5 amp)  
 FM NO. 1 (5 amp)  
 FM NO. 2 (5 amp)  
 VHF (5 amp)  
 INV POWER (5 amp)

(3) A 28-volt battery supplies power to a battery relay (K6) for emergency power to the essential bus. Battery power is routed to the nonessential bus by nonessential relay (K2).

b. Audio Control Panel. The pilot and copilot audio control panels receive 28 vdc from ICS circuit breaker through TB 19, terminal A 15. The 28 vdc leaves TB19 on terminal A16 and B16 and is routed directly to connector P214 and P215, pin S of the pilot's and copilot's audio controls panels. Crew audio control panel power is routed from the ICS circuit breaker directly to panel connector P213, pin S.

c. No. 1 Fm Facility. The No. 1 FM radio receives 28 vdc from FM NO. 1 circuit breaker through pin D of connector P209.

d. No. 2 Fm Facility. The No. 2 FM radio receives 28 vdc from FM NO. 2 circuit breaker through pin D of connector P207.

e. Vhf Command Facility. The VHF command radio receives 28 vdc from VHF circuit breaker through pin D of connector P205.

f. Uhf Command Facility. The UHF command radio (AN/ARC-116) receives 28 vdc from UHF circuit breaker through pin D of connector P203. The UHF command radio (AN/ARC-51BX) receives 28 vdc from AN/ARC-51 UHF circuit breaker through pins A and B of P403.

g. A df. The adf receives 28 vdc from ADF circuit breaker through pin L of connector P227.

h. Gyromagnetic Compass Set. The gyromagnetic compass set receives 115 vac at 400 Hz from GYRO CMPS 115V AC circuit breaker through pin C and pin R of connector P202.

i. Inverter. The inverter receives 28 vdc from INV PWR circuit breaker and supplies 115 vac at 400 Hz to GYRO CMPS 115V AC circuit breaker.

j. Transponder Radio. The transponder radio receives 28 vdc from IFF circuit breaker through pin 2 of connector P232.

k. Transponder Control. The transponder control receives 28 vdc from IFF circuit breaker through pin 51 of connector P232.

1. Transponder Computer. The transponder computer receives 28 vdc from pin 6 of connector P234 on the transponder radio. The 28 vdc enters

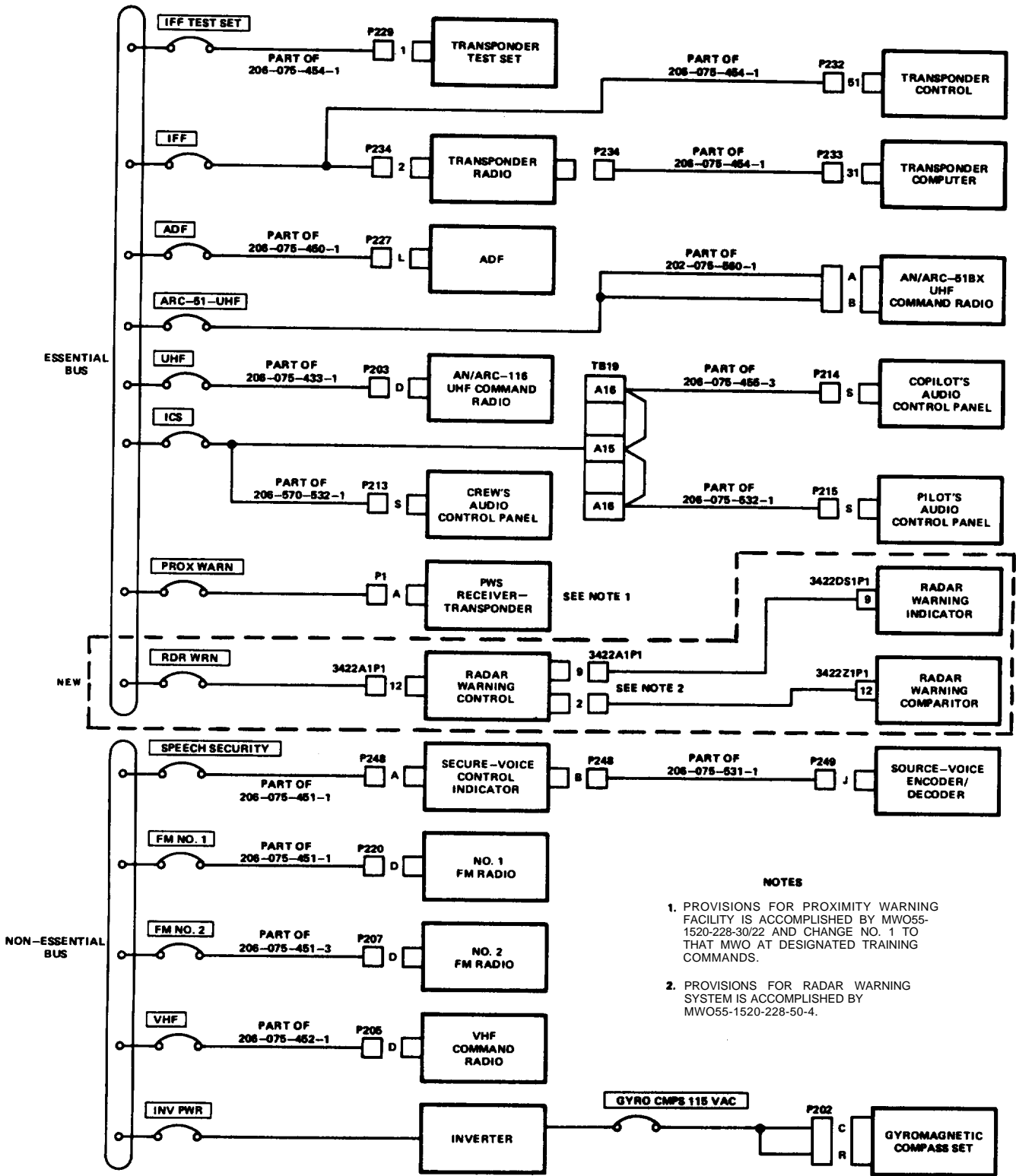

EL2M2001

Figure 2-1. Primary power application schematic diagram

the transponder computer at pin 31 of connector P233,

m. Transponder Test Set. The transponder test set receives 28 vdc from IFF TEST SET circuit breaker through pin 1 of connector P229.

n. Secure-Voice Control Indicator. The secure-voice control indicator receives 28 vdc from SPEECH SECURITY circuit breaker through pin A of connector P248.

o. Secure-Voice Encoder/Decoder. The secure-voice encoder/decoder receives power from pin B of connector P248 on the secure-voice control indicator and enters secure-voice encoder/decoder on pin J of connector P249.

p. Proximity Warning Facility. The proximity warning transponder receives 28 vdc from PROX WARN circuit breaker through pin A of connector PI.

q. Radar Warning Control Unit. The radar warning control unit receives 28 Vdc from RDR WRN circuit breaker through pin 12 of connector 3422A1P1.

r. Radar Warning Comparator. The radar warning comparator receives 28 Vdc from pin 2 of connector 422A1P1 on the radar warning control unit.

s. Radar Warning Indicator. The radar warning indicator receives 28 Vdc from pin 9 of connector 422A1P1 on the radar warning control unit.

### 2-3. Receive Audio

a. No. 1 Fm Facility (figs. FO-3 and 104). The No. 1 FM facility secure-voice mode (cipher) is activated by setting PLAIN-CIPHER toggle switch located on the front panel of the secure-voice control indicator (C-8157/ARC) to the CIPHER position. Secure-voice audio signals from the No. 1 FM radio are routed from pin C of connector J209 to secure-voice encoder/decoder, connector J249, pin D, for decoding then out of pin F of connector J250 to impedance-matching network connector J600, pin 43. The audio signal is routed through impedance-matching network, connector J600, pin 43, then to the pilot's and copilot's audio control panels, connectors J214 and J215 (pin KK on each connector). When the No. 1 FM radio is in T-R-GUARD mode and the PLAIN-CIPHER toggle switch is in CIPHER position, received guard signals are routed from No. 1 FM radio connector J209, pin b, to secure-voice encoder/decoder connector J249, pin F, then out of connector J250, pin F. In systems incorporating MWO 55-1520-228-20/1, the signal path described above is broken at connector J249, pin F. If the signal does not require decoding (PLAIN-CIPHER toggle switch in PLAIN position), it is routed from pin D connector J209 of No. 1 FM radio to secure-voice encoder/decoder pin G of connector J249, and out again at pin F of connector J250. The path from pin F of connector J250 is identical to that for decoded data. On helicopters having the audio threshold installed, the signal from pin D, connector J209 of No. 1 FM radio is

routed to Audio Threshold System connector J251, pin C2 and from pin B2 to secure-voice encoder/decoder pin G of connector J249, and out again at pin F of connector J250. The path from pin F of connector J250 is identical to that for decoded data.

b. No. 2 Fm Facility (fig. FQ-3). The No. 2 FM radio audio is routed from pin d of connector P207 to impedance-matching network connector J600, pin 41, then through J600, pins 41 and 42, to the pilot's, copilot's, and crew's audio control panels, connectors P214, P215, and P213 (pin EE on each connector).

c. Vhf Command Facility (fig. 2-2). The vhf command facility audio signals are routed from VHF command radio connector P205 pin D to impedance-matching network plug J600, pin 39. From impedance-matching network, the audio signals are distributed from J600, pin 39 to the pilot's audio control panel connector P214, pin PP, and from J600, pin 40, to copilot's and crew's audio control panel, connectors P215 and P213.

d. Uhf Command Facility (AN/ARC-116) (fig. 2-5). The uhf command facility audio output signal is routed from UHF command radio connector P203, pin D, to impedance-matching network connector J600, pin 37. From impedance-matching network, the audio signals are distributed from J600, pin 37, to the pilot's audio control panel, connector P214, pin SS, and from J600, pin 38, to copilot's and crew's audio control panel, connectors P215 and P213, pins SS.

e. Uhf Command Facility (AN/ARC-51BX) (fig. FO-9). The uhf command facility audio output signal is routed from UHF command radio (ARC-51BX) connector P401, pin F, to ARC-1 16 UHF command radio connector P203, pin D, to impedance-matching network connector J600, pin 37. From impedance-matching network, the audio signals are distributed the same way as they are for the radio set (ARC-116) (fig. 2-5) from J600, pin 37, to the pilot's audio control panel connector P214, pin SS, and from J600, pin 38, to copilot's and passenger's audio control panels, connectors P215 and P213, pins SS.

f. Adf (fig. FO-5). The adf audio signals are routed from adf receiver connector P227, pin A, to pin 35 of impedance-matching network connector J600. From impedance-matching network, the audio signals are distributed from J600, pin 35, to pilot's audio control panel connector P214, pin WW, and from J600, pin 36 to copilot's and crew's audio control panels, connectors P215 and P213, pins WW.

g. Transponder (fig. FO-6). The transponder audio signals are routed from transponder radio connector P234, pin 9, to impedance-matching network connector J600, pin 29. From impedance-matching network, the audio signals are distributed from J600, pin 29, to pilot's audio control

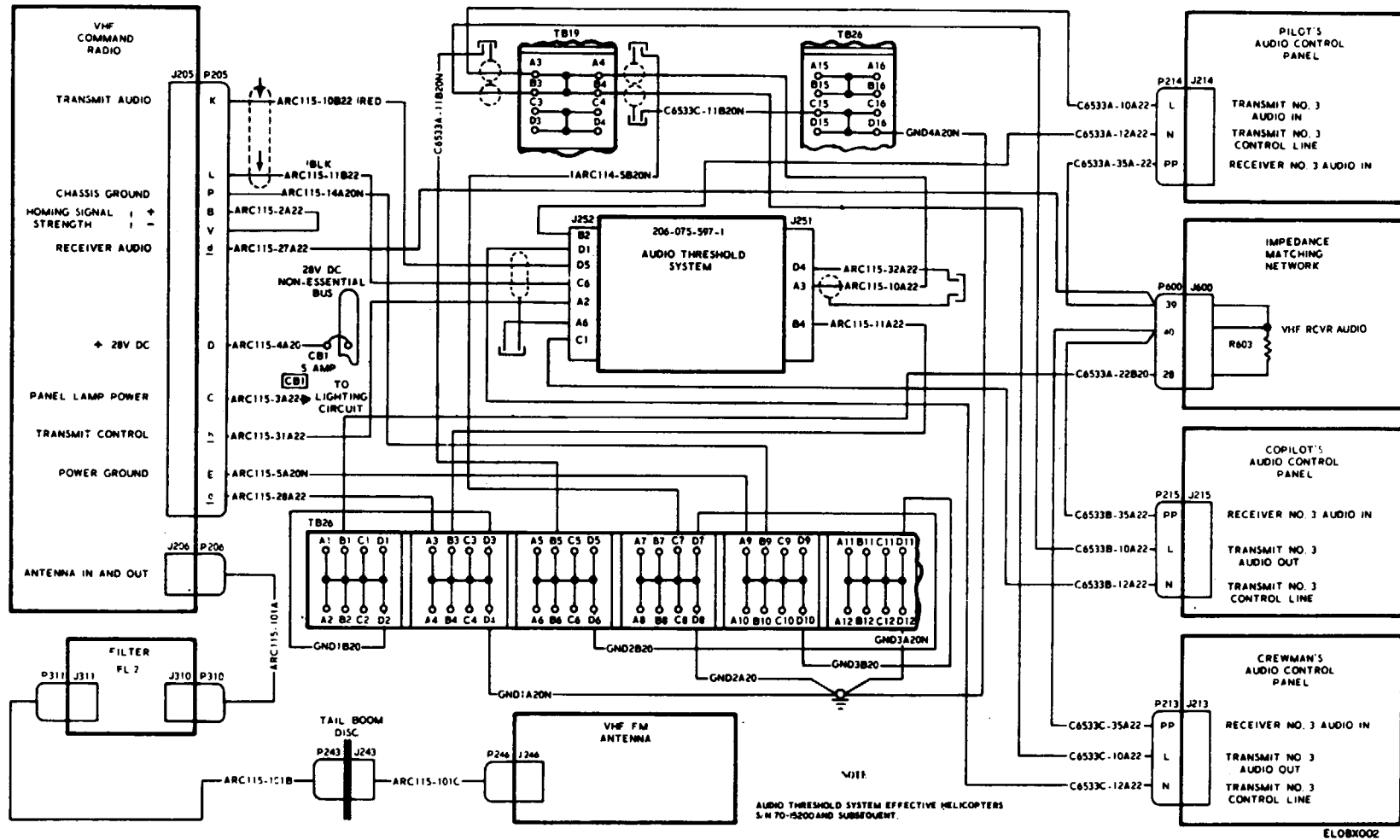

Figure 2-2. Vhf command facility interunit, schematic diagram.



bined at TB19, and transmit audio is routed from terminal C2 to No. 2 FM radio connector P207, pin K. On helicopters having audio threshold installed, transmit audio is routed from terminal C2, TB19 to Audio Threshold System connector J251, pin C4. The audio is attenuated slightly in the Audio Threshold System and appears at connector J252 on pin C5. It is then routed to No. 2 FM radio connector P207, pin K.

c. Vhf Command Facility (fig. 2-2). The vhf command facility transmit audio is routed from the pilot's audio control panel connector P214, pin L, to terminal A3 on TB19; from the copilot's audio control panel connector P215, pin L to terminal B3 on TB19; and from the crew's audio control panel connector P213, pin L, to terminal B4 on TB19. At TB19, A3, A4, B3, and B4 are combined, and transmit audio is routed from pin A4 to VHF command radio connector P205, pin K. On helicopters having audio threshold installed, transmit audio is routed from TB19, pin A4 to Audio Threshold System connector J251, pin A3. The audio is attenuated slightly in the Audio Threshold System and appears at connector J252 on pin D5. It is then routed to VHF command radio connector P205, pin K.

d. Uhf Command Facility (AN/ARC-116) (figs. 2-5 and 2-6). The uhf command facility transmit audio is routed from the pilot's audio control panel connector P214, pin R, to terminal C3 on TB19; from the copilot's audio control panel connector P215, pin R to terminal D3 on TB19; and from crew's audio control panel connector P213, pin R, to terminal D4 on TB19. At TB19, C3, C4, D3, and D4 are combined and transmit audio is routed from C4 to UHF command radio connector P203, pin K. On helicopters having audio threshold installed, transmit audio is routed from C4 of TB19 to Audio Threshold System connector J251, pin A4. The audio is attenuated slightly in the Audio Threshold System and appears at connector J252 on pin D6. It is then routed to uhf command radio connector P203, pin K.

e. Uhf Command Facility (AN/ARC-,51BX) (fig. 2-5 and FO-9). The uhf command facility transmit audio is routed from the pilot's audio control panel connector P214, pin P, to terminal C3 on TB19; from the copilot's audio control panel connector P215, pin R, to terminal D3 on TB19; and from crew's audio control panel connector P213, pin R, to terminal D4 on TB19 (fig. 2-5). At TB19, terminals C3, C4, D3, and D4 are combined and transmit audio is routed from C4 to ARC-1 16 UHF command radio connector P203, pin K. The transmit audio is routed from P203, pin K, to

UHF command radio (ARC-51BX) connector P403, pin V (fig. FO-9).

#### 2-5. Retransmit Audio (fig. FO-3)

Received audio is routed from No. 1 FM radio connector P209, pin X, to terminal board TB19, terminal A 13. Audio is routed from TB19, terminal A14, to No. 2 FM radio connector P207, pin Y, for transmission. Received audio from No. 2 FM facility connector P206, pin X, is routed to terminal board TB19, terminal A1 1. Audio is routed from TB19, terminal A12, to No. 1 FM radio connector P209, pin Y, for transmission.

#### 2-6. Pilot's Audio (fig. FO-7)

a. Receive Audio. The audio output from pilot's audio control panel J214, pin TT is routed to TB21, C2/D2 and then to the pilot's headset microphone cable. The headset return is routed to TB21, B3/A3 and then to ground. The control panel audio return J214, pin XX is connected to the same ground point,

b. Transmit Audio. The audio output (high) from the pilot's microphone is routed to TB21, B2/A2 and then to J214, pin C on the pilot's audio control panel. The low output from the microphone is routed to TB21, D1/C1 and then to J214, pin A on the pilot's audio control panel.

#### 2-7. Copilot's Audio (figs. FO-7 and FO-8)

a. Receive Audio. On helicopters without threshold, the audio output control panel J2 15, pin TT is routed to TB21, A7/B7 and then to the copilot's headset-microphone cable. The headset return is routed to TB21, D7/C7 and then to J215, pin XX and ground. On helicopters having Audio Threshold System installed, the audio output from the copilot's audio control panel J215, pin TT is routed to TB21, C7/D7 and then to the copilot's headset-microphone cable. The headset return is routed to TB21, D8/C8 and then to J215, pin XX and ground.

b. Transmit Audio. On helicopters without audio threshold, the audio output (high) from the copilot's microphone is routed to TB21, B5/A5 and then to J215, pin C on the copilot's audio control panel. The low output from the microphone is routed to TB21, D5/C5 and then to J215, pin A on the copilot's audio control panel. On helicopters having Audio Threshold System installed, the audio output (high) from the copilot's microphone is routed to TB21, B7/A7 and then to J215, pin C on the copilot's audio control panel.

The low output from the microphone is routed to TB21, B8/A8 and then to J215, pin A on the co-pilot's audio control panel.

## 2-8. Crewmen's Audio

(figs. F0-7 and F0-8)

*a. Receive Audio.* On helicopters without audio threshold, the audio output from the crew's audio control panel J213, pin TT is routed to TB21, A8/B8 and then to the crew's headset-microphone cable. The headset return is routed to TB21, D8, then C8, to J215, pin XX and ground. On helicopters having Audio Threshold System installed, the audio output from the crew's audio control panel J213, pin TT is routed to the crew's headset-microphone cable. The headset is routed to J213, Pin xx and ground.

*b. Transmit Audio.* On helicopters without audio threshold, the audio output (high) from the crew's microphone is routed to TB21, B6/A6 and then to J213, pin C on the crew's audio control panel. The low output from the microphone is routed to TB21, D6/C6 and then to J213, pin A on the crew's audio control panel. On helicopters having audio threshold installed, the audio output (high) from the crew's microphone is routed to J213, pin C on the crew's audio control panel. The low output from the microphone is routed to J213, pin A on the crew's audio control panel.

## 2-9. Pilot's Microphone Keying Circuit

(fig. F0-7)

*a. Radio Keying.* The pilot's radio keying circuit is from ground to the moving contact of S104

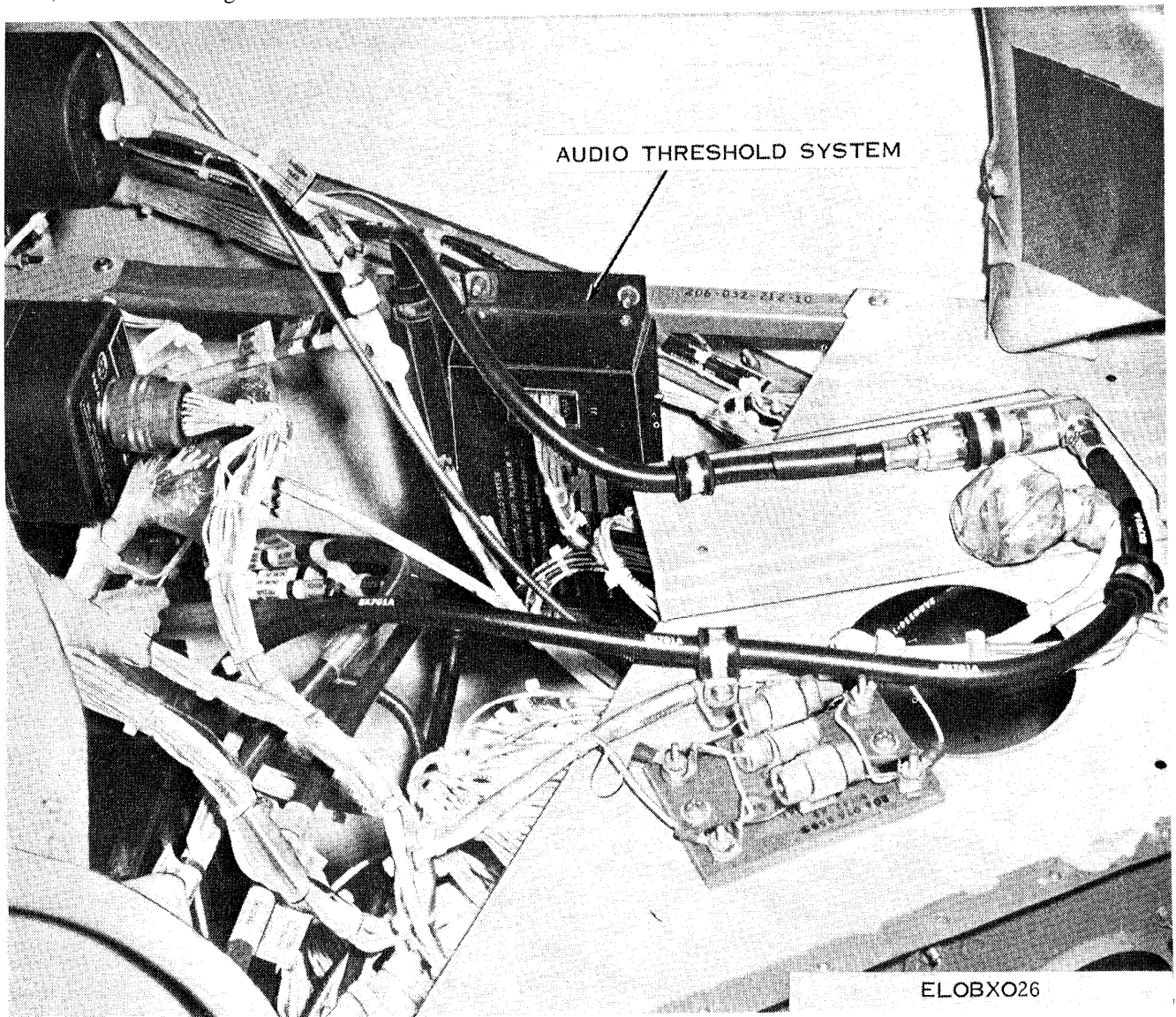

Figure 2-4. Audio Threshold System (view looking up from right side of helicopter at nose area forward of (behind) instrument panel.



# TURNOVER LOG

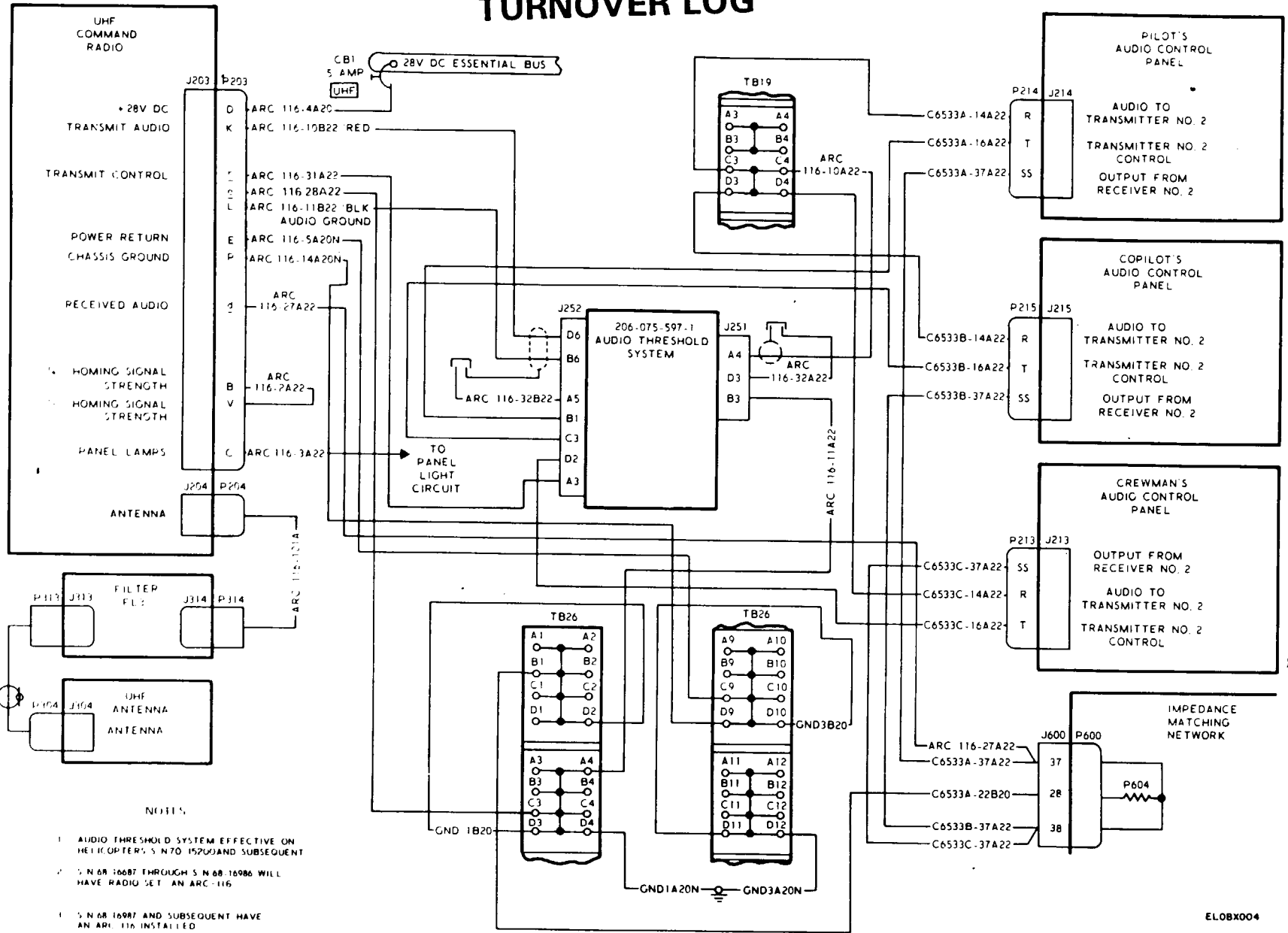
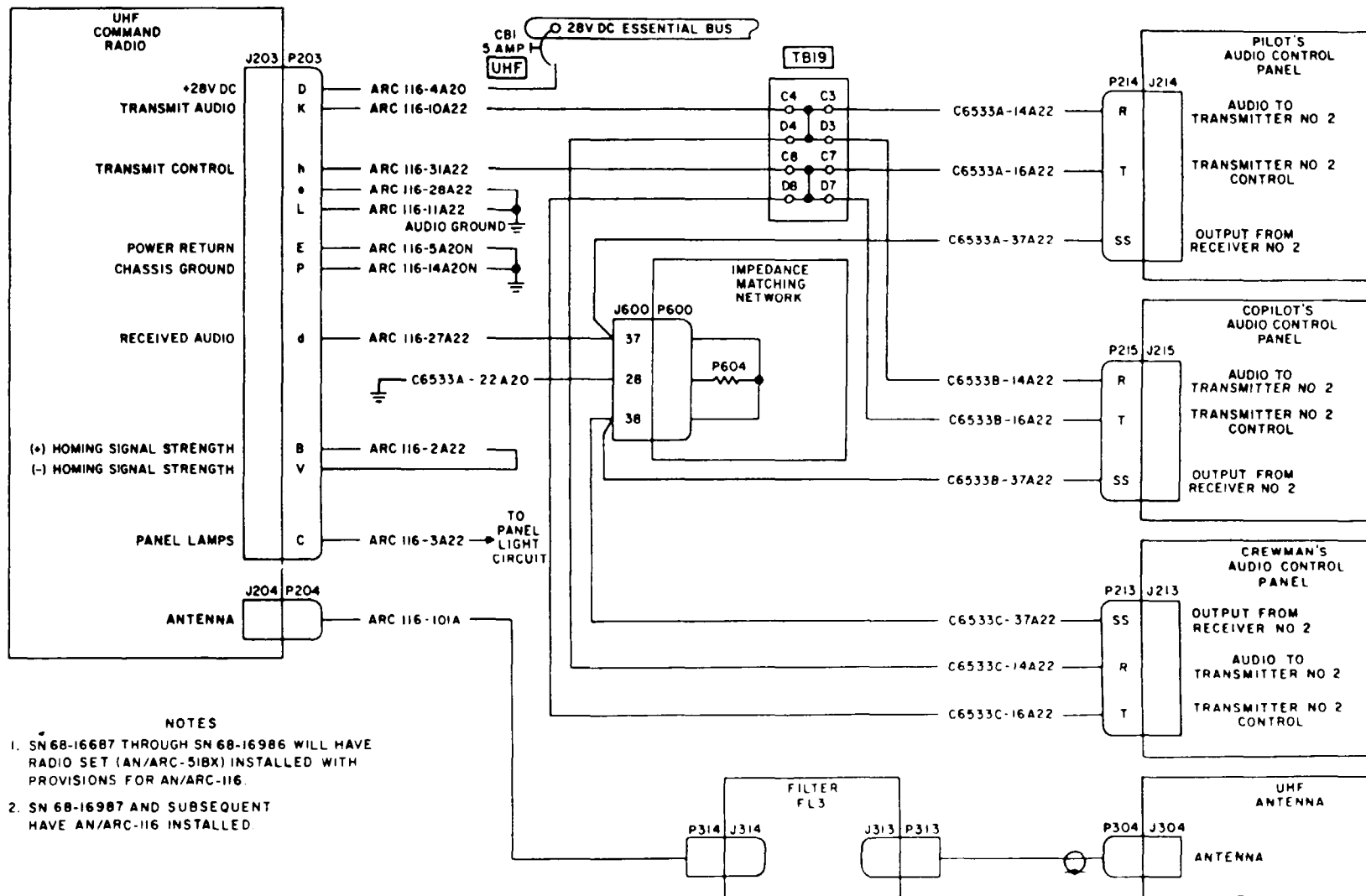

Figure 2-5. Uhf command facility (AN/ARC-116) interunit schematic diagram.

ELOBX004



- NOTES
1. SN 68-16687 THROUGH SN 68-16986 WILL HAVE RADIO SET (AN/ARC-51BX) INSTALLED WITH PROVISIONS FOR AN/ARC-116.
  2. SN 68-16987 AND SUBSEQUENT HAVE AN/ARC-116 INSTALLED.

EL0BX005

Figure 2-6. Uhf command facility (AN/ARC-116) interknit schematic diagram without Audio Threshold System.

and from the radio terminal on S104 to TB20, D9/C9, then to J214, pin B on the pilot's audio control panel.

b. *ICS Keying*. The pilot's ICS keying circuit is from ground to the moving contact of S104 and from the ICS terminal on S104 to TB20, D11/C11, then to J214, pin E on the pilot's audio control panel.

#### 2-10. Copilot's Microphone Keying Circuit (fig. FO-7)

a. *Radio Keying*. The copilot's radio keying circuit is from ground to the moving contact of S105 through J2 16, pin D and from the radio terminal on S105 through J216, pin C to terminal 1 on the copilot's foot switch to TB20, A10/A9, then to J215, pin B on the copilot's audio control panel. In addition, there is a circuit from ground to terminal G on S103 and from terminal 1 to TB20, A10/A9, then to J215, pin B of the copilot's audio control panel.

b. *ICS Keying*. The copilot's ICS keying circuit is from ground through P216, pin D to the moving contact of S105 and from the ICS terminal on S105 through P216, pin E, to TB20, B11/A11, then to J215, pin E on the copilot's audio control panel.

#### 2-11. Crew's Microphone Keying Circuit (figs. FO-7 and FO-8)

a. *Radio Keying*. On helicopters without audio threshold, the crew's radio keying circuit is from ground through the crew's keying switch to TB21 D3/C3 then to J213, pin B on the copilot's audio control panel. On helicopters with Audio Threshold System installed, the crew's radio keying circuit is from ground through the crew's keying switch to J213, pin B on the copilot's audio control panel.

b. *ZCS Keying*. The crew's ICS keying line is not used.

#### 2-12. Rf Receive-Transmit Signals (fig. FO-3)

a. *No. 1 Fm Facility*. Rf signals from J245 on the VHF/FM antenna are routed through J242/P242 on the tailboom disc to J237 on filter FL1. Signals pass through the filter to connector J239 and from there to the No. 1 FM radio, connector J210 (communications antenna). The rf homing signals at J240 on the right homing antenna and J241 on the left homing antenna are routed to the No. 1 FM radio homing antenna inputs, J212 and J211.

b. *No. 2 Fm Facility* (fig. FO-3). Rf signals from J238 on FM antenna No. 2 are routed to

J315 on filter FL4. Signals pass through the filter to connector J316 and from there to the No. 2 FM radio, connector J208.

c. *Vhf Command Facility* (fig. 2-2). Rf signals from J246 on the VHF/FM antenna are routed through J243/P243 on the tailboom disk to J311 on filter FL2. Signals pass through the filter to connector J310, then to J206 (communications antenna) on the VHF command radio.

d. *Uhf Command Facility (AN/ARC-116)* (fig. 2-5). Rf signals from J304 on the uhf antenna are routed to J313 on filter FL3. Signals pass through filter to J314, then to J204 (communications antenna) on the UHF command radio.

e. *Uhf Command Facility (AN/ARC-51BX)* (fig. FO-9). Rf signals from J304 on the uhf antenna are routed to J313 on filter FL3. Signals pass through filter FL3 and out J314, where they are further routed through P204/J406 to P404/J404 on the UHF receiver-transmitter.

f. *Adf* (fig. FO-5). Rf signals at the adf sense antenna are directly routed to the impedance-matching amplifier. The output of the impedance-matching amplifier J226 is routed to the sense antenna input of the adf receiver J221. The rf signals at the loop antenna outputs J224 and J225 are connected to the adf receiver loop antenna inputs J222 and J223.

g. *Transponder* (fig. FO-6). Rf signals at the transponder antenna output J236 are routed to J235B on the transponder test set. The signal is then routed from J235A of the transponder test set to J230 on the transponder radio. If the transponder test set is not installed, connector P235A and P235B are mated through an in-line connector, and the rf signals are routed from the transponder antenna jack (J236) directly to transponder radio jack J230.

#### 2-13. Homing Signals to Heading-Radio Bearing Indicator (fig. FO-3)

a. *Signal Adequacy Signal*. The signal adequacy control occurs in the No. 1 FM radio when received signal is strong enough for homing. The adequacy signal appears as a ground on No. 1 FM radio connector J209, pin A. Positive 28 volts dc comes from the 28-volt dc nonessential bus through the Fm No. 1 circuit breaker. It is routed from that breaker to terminal board TB19, terminals A 10 and B-9, then to pin X of heading-radio bearing indicator connector J201. Ground return for this voltage is through J201 pin Y, J209, pin A, and the control in the No. 1 FM radio.

b. *Station Approach Signal*. The station approach signal developed in the No. 1 FM radio is

present at J209, pins B and V, and is routed to J201, pins V and W, on the heading-radio bearing indicator.

c. *Steering Indicator Signal.* The steering indicator signal developed in the No. 1 FM radio is present at J209, pins U and T, and is routed to capacitor board assembly A3, pins 1 and 2, respectively. The signal is then routed from pins 3 and 4 of A3 to J201 pins U and T, respectively of the heading-radio bearing indicator.

## 2-14. Adf Signals

(fig. FO-5)

a. *Heading Synchro Signals.* The heading synchro signal is a three-wire signal from the adf receiver to the heading-radio bearing indicator. One wire is common and is connected to ground. The first wire is from J227, pin K, on the adf receiver to J201, pin P on the heading-radio bearing indicator. The second wire is from J227, pin R, to J201, pin R. The third wire (common wire) is routed from J227, pin J, to TB20 A3/B3/A4 and to J201, pin S, and is grounded because J227, pin J is connected to J227, pin C, internally in the adf receiver. J227, pin C is grounded.

b. *Synchro Excitation Signal.* The synchro excitation signal output at J227, pin F, of adf receiver is routed to J201, pin N, (receiver synchro excitation input) of heading-radio bearing indicator and back to J227, pin D (transmitter synchro excitation input) of adf receiver J227, pin G (transmitter synchro return) of the adf receiver is grounded. J201, pin M (receiver synchro excitation return), of the heading-radio bearing indicator is routed to TB20 terminal (B3/A4/A3 and is grounded as explained in a above. J227, pin H (transmitter synchro excitation return) of the adf receiver is grounded.

## 2-15. Gyromagnetic Compass Set

(fig. 2-7)

a. *Dg Stabilized Reference Signal.* The dg stabilized reference signal is a three-wire signal from the directional gyro to the heading-radio bearing indicator. The first wire is routed from J202, pin H, on the directional gyro to J201, pin C, on the heading-radio bearing indicator. The second wire is routed from J202, pin J, to J201 pin D. The third wire is routed from J202, pin G, to J201, pin E.

b. *115 Vac 400 Hz Excitation.* Excitation for the directional gyro transmitter synchro is routed from the GYRO CM PS circuit breaker on the overhead console to J202, pin R, of the directional gyro. The excitation return is from J202, pin S, to ground.

c. *24 Vac 400 Hz Excitation.* Excitation for the compass transmitter is routed from J202, pin M, of the directional gyro to the TR101 -E of the compass transmitter.

d. *Compass Transmitter Output Signal.* The compass transmitter output signal (which is the differential synchro input of the heading-radio bearing indicator) is a three-wire signal. The first wire is routed from TR101-B on the compass transmitter to J201: pin F, on the heading-radio bearing indicator. The second wire is routed from TR101-C to J201, pin G. The third wire is routed from TR101-A to J201, pin H.

e. *Differential Synchro Output Signal.* The differential synchro output signal (error signal) is a three-wire signal from the heading-radio bearing indicator to the directional gyro. The first wire is routed from J201, pin J of the heading-radio bearing indicator to J202, pin W of the directional gyro. The second wire is routed from J201, pin K to J202, pin X. The third wire is routed from J201, pin L to J202, pin Y.

f. *Slaving Synchro Output Signal.* The slaving synchro output signal is routed from J202, pins V and U to J202, pins T and B, respectively, on the directional gyro.

g. *DIR GYRO-MAG Switch.* A dc voltage is routed from J202 pin P on the directional gyro to terminal 1 of the DIR GYRO-MAG switch. Terminal 2 of the DIR GYRO-MAG switch is routed to J202 pin E on the directional gyro.

h. *Annunciator Signal.* The annunciator signal is routed from J202 pins a and b of the directional gyro to J201 pins d and e, respectively, of the heading-radio bearing indicator.

i. *Compass Power Failure Flag Signal.* The dc voltage at terminal 1 of the DIR GYRO-MAG switch (g above) is routed to J201 pin Z. J201 pin a is routed to ground to provide a return circuit for the signal.

## 2-16. Transponder

(fig. FO-6)

a. *Code Select Signals.* The mode 1 A<sub>1</sub> code select signal is routed from J232 pin 26 on the transponder control to J234 pin 40 on the transponder radio. The mode 1 A<sub>2</sub> signal is routed from J232 pin 27 to J234 pin 39. The mode 1 A<sub>3</sub> signal is routed from J232 pin 28 to J234 pin 38. The mode 1 B<sub>3</sub> signal is routed from J232 pin 29 to J234 pin 37. The mode 1 B<sub>2</sub> signal is routed from J232, pin 30 to J234 pin 36. The mode 3/A A<sub>1</sub> signal is routed from J232 pin 32 to J234 pin 29. The mode 3/A A<sub>2</sub> signal is routed from J232 pin 33 to J234 pin 28. The mode 3/A A<sub>3</sub> signal is routed from J232 pin 35 to J234 pin 27. The mode



3/A B<sub>1</sub> signal is routed from J232 pin 36 to J234 pin 26. The mode 3/A B<sub>2</sub> signal is routed from J232 pin 37 to J234 pin 25. The mode 3/A B<sub>3</sub> signal is routed from J232 pin 38 to J234 pin 24. The mode 3/A C<sub>1</sub> signal is routed from J232 pin 15 to J234 pin 43. The mode 3/A C<sub>2</sub> signal is routed from J232 pin 16 to J234 pin 44. The mode 3/A C<sub>3</sub> signal is routed from J232 pin 17 to J234 pin 50. The mode 3/A D<sub>1</sub> signal is routed from J232 pin 18 to J234 pin 56. The mode 3/A D<sub>2</sub> signal is routed from J232 pin 19 to J234 pin 57. The mode 3/A D<sub>3</sub> signal is routed from J232 pin 20 to J234 pin 58.

*b. MASTER Switch Control Signals.* The power relay signal is routed from J232 pin 11 on the transponder control to J234 pin 20 on the transponder radio. The standby control signal is routed from J232 pin 8 to J234 pin 16. The sensitivity control signal is routed from J232 pin 10 to J234 pin 14. The emergency control signal is routed from J232 pin 5 to J234 pin 19.

*c. Mode Test Signals.* The test mode control signal is routed from J232 pin 24 on the transponder control to J234 pin 4 on the transponder radio. The mode 1 test signal is routed from J229 pin 4 on the transponder test set to J232 pin 40 on the transponder control. The mode 2 test signal is routed from J229 pin 5 to J232 pin 41. The mode 3/A test signal is routed from J229 pin 6 to J232 pin 43.

*d. Mode Enable Signals.* The mode 1 enable signal is routed from J232 pin 25 of the transponder control to J234 pin 22 of the transponder radio. The mode 2 enable signal is routed from J232 pin 9 to J234 pin 15. The mode 3/A enable signal is routed from J232 pin 6 and routed to J234-18.

*e. Mode 4 Signals.* The mode 4 video-out signal is routed from J234 pin 45 on the transponder radio to J233 pin 2 on the transponder computer. The mode 4 enable signal is routed from J234 pin 46 to J233 pin 3. The mode 4 reply signal is routed from J233 pin 1 to J234 pin 47. The mode 4 disparity signal is routed from J233 pin 4 to J234 pin 48. The mode 4 disable signal is routed from J232 pin 23 on the transponder control to J233 pin 14 on the transponder computer. The mode 4 A/B select signal is routed from J232 pin 48 to J233 pin 9.

*f. Other Signals.* The monitor control signal is routed from J232 pin 45 on the transponder control to J229 pin 3 on the transponder test set. The test set light signal is routed from J232 pin 46 to J229 pin 8. The refuel hold signal is routed from J232 pin 1 to J233 pin 37 on the transponder computer. The verify bit No. 1 signal is routed from J232 pin 3 to J233 pin 19. The reply light enable signal is routed from J232 pin 42 to J234 pin 34. The I/P control signal is routed from J232 pin 2 to J234 pin 21. The zeroize return signal is routed from J232 pin 22 to J233 pin 33. The code 2 zeroize and alarm signal is routed from J233 pin 17 on the transponder computer to J234 pin 52 on the transponder

radio. The caution light signal is routed from J234 pin 53 to J233 pin 28. The computer hold signal is routed from S102 center contact (IFF CODE HOLD switch) to J233 pin 32 on the transponder computer. The IFF MODE 4 light signal is routed from the essential bus through the IFF circuit breaker and a set of contacts of IFF CODE HOLD switch S102. The switch contacts to the light are closed when the switch is on. The caution light signal is routed from J233 pin 30 to the caution light on the instrument panel.

### 2-16.1. Radar Warning AN/APR-39 System (fig. FO-10)

*a. Power Distribution.* The RDR WRN circuit breaker, when depressed, applies 28 Vdc power from the essential bus to the control panel 3422A1P1 pin 12. With the PWR switch on the control panel positioned to ON, 28 Vdc power is routed from 3422A1P1 pin 9 and pin 2 to the indicator 3422 DS1P1 pin 9 and to the comparator 3422Z1P1 pin 12.

*b. Self Test Mode.* Depressing the SELF TEST switch on the control panel, routes the self test circuit from 3422A1P1 pin 3 to comparator 3422Z1P1 pin 13, and from 3422A1P1 pins 7 and 17, the self test forward is routed to the dual receiver 3422RE1P5, the self test aft is routed through 3422P1 pin C to the dual receiver 3422 RE2P5.

*c. Visual Display.* The radar warning indicator displays signals received by the spiral antennas. The forward right and left antennas received signals are routed to the dual receiver and then to the comparator 3422Z1P1 pins 8 and 9. The aft right and left antennas received signals are routed to the dual receiver and then through 3422P1 pins A and B to the comparator 3422Z1P1 pins 18 and 19. The signals are processed and routed from 3422Z1P1 pins 1 through 5 to the radar warning indicator 3422DS1P1 pins 1 through 5. The radar warning indicator also displays signals received by the blade antenna. With the DSCRM switch on the control panel positioned to ON signals are routed from 3422A1P1 pin 4 to the comparator 3422Z1P1 pin 14 to arm the missile alert circuit. Signals are then routed from the blade antenna 3422E1P1 to the comparator 3422Z1P2. MA lamp signals are routed from the comparator 3422Z1P1 pin 15 to the control panel 3422A1P1 pin 5 and out pin 7 to the radar warning indicator 3422 DS1P1 pin 7.

*d. Audio Signals.* When visual display signals are received by the radar warning indicator audio signals are created and routed from the radar warning indicator 3422DS1P1 pin 8 to the control panel 3422A1P1 pin 8, through the radar warning control panel and out 3422A1P1 pin 14 to the interphone communication system.

*e. Panel Lighting.* The control panel receives 28 Vdc when the interior lights control is operated. Power is

routed from TB6 terminal 5 to the control panel 3422A1P1 pin 13. Refer to TM 55-1520-228-20 for

operation of the interior lights.

---

## Section II. EQUIPMENT FUNCTIONAL DESCRIPTION

---

### 2-17. General

This section covers functional details of electronic equipment not presently covered by separate technical manuals.

#### 2-18. Static Inverter

The inverter requires 28 vdc input from the nonessential bus to supply 115 vac at 400 Hz to the gyromagnetic compass set. The inverter is housed in a sealed rectangular metal case, and electrical connection is accomplished by a six-pin, quick-disconnect plug mounted on one end of the unit.

#### 2-19. Impedance-Matching Network

The impedance-matching network consists of components soldered to a printed circuit card. The components are protected from moisture and fungus by a fungus-resistant varnish. One edge of the card plugs into a connector; the comers opposite this edge contain mounting-screw holes. Eight 150-ohm resistors provide audio signal loading and distribution. Three diodes provide dc blocking for electrical system tests. The re-

maining parts are used in the armament system. Refer to TM 55-1520-228-20 for a detailed description of that portion of the impedance-matching network not used in the helicopter audio circuits.

#### 2-20. Storage Battery

The battery is contained in a sealed rectangular fiberglass case. Two flexible hoses extending from the top of the case to the helicopter exterior provide vents. Electrical connection is made by a two-pin, quick-disconnect plug mounted at one end of the case. Refer to TM 11-1520-228-20 for further information concerning the battery.

#### 2-21. Capacitor Board

The capacitor board consists of three capacitors and a resistor mounted on a board by clamps and soldered to terminals. Aircraft wiring is attached to the terminals by lugs. The capacitor board provides a capacitive load for the No. 1 FM radio homing steering signals. The load provides damping for the radio bearing needle in the heading-radio bearing indicator.

## CHAPTER 3

### DIRECT SUPPORT MAINTENANCE

---

#### Section I. MAINTENANCE TECHNIQUES

##### 3-1. General Instructions

The direct support electronic equipment configuration maintenance procedures in this manual supplement the organizational maintenance procedures in TM 11-1520-228-20. These procedures also supplement the separate technical manuals on the electronic equipment to provide complete repair and maintenance instructions. The systematic maintenance procedures begin with the functional operation and sectionalization checks that can be performed by organizational and direct support maintenance personnel within the helicopter, and are extended to removal and replacement of units or components from the helicopter. When the components are removed from the helicopter the systematic maintenance procedures continue with the bench maintenance of the individual electronic equipment components. Section II of this chapter provides direct support troubleshooting and repair of the electronic equipment configuration within the helicopter and supplements the organizational maintenance procedures. Section III provides direct support troubleshooting of electronic equipment components that have been removed from the helicopter.

##### **WARNING**

Dangerous voltages exist in this configuration. Be careful when working around the 115-volt ac output of the inverter. The 115-volt ac is present throughout the gyromagnetic compass facility wiring.

##### **CAUTION**

To avoid transistor and integrated circuit damage, make certain that all electronic equipment function and source power switches are in the OFF position before changing cable connections. Check the source voltage and polarity before making connections. **TRANSISTORS AND INTEGRATED CIRCUITS MAY BE PERMANENTLY DAMAGED BY IMPROPER VOLTAGE OR POLARITY.**

##### 3-2. Organization of Troubleshooting Procedures

###### a. General. Troubleshooting the electronic

equipment configuration in Army Model OH-58A helicopter is performed in three steps. The first step, sectionalization, traces the fault to a facility used in a system of the configuration. The second step, localization, traces the trouble to the defective unit that is part of the faulty facility and/or associated cabling or wiring. When performing bench maintenance on a removed electronic equipment component, localization includes tracing the fault to a defective stage or module within the component. The third step, isolation, isolates the trouble within the component to a defective part.

b. Sectionalization. Listed below is a group of tests arranged to reduce unnecessary work and to aid in tracing troubles to the defective facility.

(1) Visual inspection. Visual inspection is used to locate faults before operating or testing circuits. The seating of all component connectors, connections to switches and circuit breakers, connections on terminal boards, connections to antennas, etc., should be observed and an attempt made to locate the fault.

(2) Operational tests. Operational tests frequently indicate the general location of trouble. In many instances, the tests will help in determining the exact nature of the fault. The periodic preventive maintenance checks and services chart (TM 11-1520-228-20) may be used as an operational test.

c. Localization. The procedures listed below are used for localizing troubles within an electronic system or facility to the faulty component or unit.

(1) Electronic configuration performance tests. The periodic preventive maintenance checks and services chart tests (TM 11-1520-228-20) are used in conjunction with the troubleshooting charts to locate faulty basic signal equipment items.

(2) Resistance measurements. Use the configuration voltage and resistance charts (paras 3-13 and 3-14) to find normal readings and compare them to the actual readings taken.

(3) Troubleshooting chart. The troubleshooting chart with troubles and symptoms will aid in localizing the trouble to a component or subassembly. If the corrective measures indicated



do not restore normal equipment operation, troubleshooting the cord and cables may be necessary. When the trouble is isolated to an installation item, remove the item from the helicopter and replace it with an installation item known to be in working order. When the trouble is isolated to equipment, remove the equipment from the helicopter for bench testing and replace it with one known to be in good working order. Note on the repair tag how the equipment performed and what corrective measures were taken.

(4) *Intermittent troubles.* In all tests, the possibility of intermittent troubles should not be overlooked. If present, this type of trouble often may be made to appear by tapping or jarring the equipment and checking wiring and connections to the components.

d. Isolation. After the trouble has been localized (c above), the methods in (1) through (4) below will aid in isolating the trouble to a defective circuit element within a component.

(1) *Voltage measurements.* This equipment is transistorized. When measuring voltages, use tape or sleeving (spaghetti) to insulate the entire test prod, except for the extreme tip. A momentary short circuit can ruin a transistor. Use the same or equivalent multimeter specified on the voltage and resistance diagrams.

(2) *Resistance measurements.* Make resistance measurements in this equipment only as directed on voltage and resistance diagrams or charts. When using the multimeter, set it to the resistance range specified on the diagrams or charts; otherwise, the indications obtained will be inaccurate.

### CAUTION

Before using any multimeter to test transistors or transistor circuits by measuring resistances, check the open-circuit voltage across the multimeter test leads. Do not use the multimeter if the open-circuit voltage exceeds 1.5 volts. Also, since the RX1 range normally connects the multimeter internal battery directly across the test leads,

the comparatively high current (50 ma or more) may damage the transistor under test. As a general rule, the RX 1 range of any multimeter should not be used when testing low-power transistors.

(3) *Intermittent troubles.* In all the tests, the possibility of intermittent troubles should not be overlooked. If present, this type of trouble often may be made to appear by tapping or jarring the equipment. Make a visual inspection of the wiring and connections to the modules of the component. Minute cracks in printed circuit board can cause intermittent operation, and may be located by means of a magnifying glass. Continuity measurements of printed conductors may be made by using techniques ordinarily used on hidden conventional wiring; observe the multimeter resistance measurement precautions discussed in (2) above.

(4) *Resistor and capacitor color code diagrams.* Resistor and capacitor color code diagrams (figs. FO-1 and FO-2) are provided to aid maintenance personnel in determining the value, voltage rating, and tolerance of capacitors and resistors.

## 3-3. Test Equipment, Tools, and Materials Required

The test equipment and tools required for troubleshooting the electronic configuration in OH-58A helicopters are as follows:

### a. *Tools.*

(1) Tool Kit, Electronic Equipment TK-100/G.

(2) Tool Kit, Electronic Equipment TK-105/G.

### b. *Test Equipment.*

(1) Multimeter TS-352B/U.

(2) Wattmeter AN/URM-120.

### c. *Materials.*

(1) Lacing twine M IL-T-713, type P class 2.

(2) Safety wire, commercial.

(3) Insulation sleeving, commercial.

(4) Solder QQ-S-571, composition SN60.

## Section II. CONFIGURATION INTERUNIT TROUBLESHOOTING

### 3-4. Introduction

a. When a malfunction of the electronic equipment occurs, the first step in correcting the trouble is to sectionalize the cause to a particular unit. Perform the operational checks in the periodic preventive maintenance checks and services chart (TM 11-1520-228-20). If the operational checks and supporting troubleshooting chart are

inconclusive as to which unit or item is causing the trouble, perform the direct support in aircraft troubleshooting procedures in this section for the particular defective facility.

b. The direct support in aircraft troubleshooting procedures involve the use of special portable test equipments that are not allocated at the organizational maintenance level. In some in-

stances, the troubleshooting procedures in this section require more than one person, since the controls for the electronic equipments and the other basic components are remotely located. The organizational maintenance repairman should remain in the cockpit and operate the controls in accordance with commands from the direct support maintenance repairman. The direct support maintenance repairman will then connect the test equipments to the equipment components and perform the required tests.

### 3-5. Test Setup

#### CAUTION

Do not connect the auxiliary power unit to the helicopter before checking with the helicopter crew chief, When connecting the auxiliary power unit to the helicopter, proceed as follows:

a. Turn the helicopter battery (BAT) switch on the dc power panel on the overhead console to the OFF position.

### 3-6. Troubleshooting the Intercommunications and Audio Facility

Fault	Probable cause	Solution
No response in one headset,	a. Defective headset. b. Defective cable.	a. Replace headset. b. Check cables and repair or replace as necessary.
No response in all headsets,	c. Defective audio control panel, a. Defective microphone, b. Defective audio control panel.	c. Replace audio control panel. a. Replace microphone. b. Replace audio control panel.
Cyclic stick switch doesn't enable ICS.	a. Defective cyclic stick switch. b. Defective cable.	a. Replace cyclic stick switch. b. Check cyclic stick switch cable and repair or replace as necessary.
Copilot's footswitch doesn't enable ICS, Volume is not variable,	Defective footswitch. Defective audio control panel.	Replace footswitch. Replace audio control Panel.

### 3-7. Troubleshooting the Liaison Facility

Fault	Probable cause	Solution
No facility audio output. No facility transmit output.	Receiver in facility is defective. a. Transmitter in facility is defective. b. Antenna is defective. c. Defective antenna cable. d. Defective Audio Threshold System.	Replace AN/ARC-114 radio. a. Replace AN /ARC-114 radio. b. Replace antenna. c. Repair or replace cable d. Replace Audio Threshold System.
Operating frequency is incorrect. One operator is unable to transmit,	Defective radio. a. Respective transmit switch is defective. b. Operator's audio control panel is defective.	Replace AN/AR-114 radio a. Replace defective switch. b. Replace operator's audio control panel,
Heading-radio bearing indicator does not indicate properly.	a. Defective facility. b. Defective heading-radio bearing indicator. c. Defective cable.	a. Replace AN/ARC-114 radio. b. Replace heading. radio bearing indicator. c. Repair or replace cable.
Squelch or volume controls do not work properly, Transmitted and received signal are weak.	Defective facility a. Defective antenna cable b. Defective antenna c. Defective Audio Threshold System.	Replace AN/ ARC-114 radio a. Repair or replace cable. b. Replace antenna. c. Replace Audio Threshold System.

#### CAUTION

Reversed polarity between the helicopter battery circuit and auxiliary power unit can damage electrical parts and cause a serious fire,

b. Connect the auxiliary power unit plug to the helicopter external power receptacle low on the right rear side of the helicopter.

#### NOTE

When the auxiliary power unit plug is inserted in the receptacle, the auxiliary power unit relay is energized and electrical power is supplied directly to the main battery bus for distribution.

c. Start the auxiliary power unit if it is not already running.

d. Turn on power by resetting the circuit breakers.

e. Set battery switch to OFF.

**3-8. Troubleshooting Uhf Command Facility (AN/ARC-116)**

Fault	Probable cause	Solution
No facility audio output	a. Receiver in facility is defective b. Audio control panel is defective	a. Replace Radio Set (AN/ARC-116). b. Replace audio control panel.
No facility transmit output	a. Transmitter in facility is defective b. Uhf antenna is defective c. Defective antenna cable d. Defective Audio Threshold System	a. Replace Radio Set (AN/ARC-116). b. Replace Uhf antenna. c. Repair or replace antenna cable. d. Replace Audio Threshold System.
Operating frequency is incorrect One operator is unable to transmit	Defective radio a. Respective transmit switch is defective. b. Operator's audio control panel is defective. c. Defective Audio Threshold System	Replace Radio Set (AN/ARC-116). a. Replace defective switch. b. Replace operator's audio control panel. c. Replace Audio Threshold System.
Improper squelch operation.....	Defective facility . . .	Replace AN/ARC-116 facility.

**3-9. Troubleshooting Uhf Command Facility (AN/ARC-51BX)**

Fault	Probable cause	Solution
No facility audio output.	a. Receiver in facility is defective. b. Control panel in facility is defective. c. Audio control panel is defective. d. Cable is defective . . .	a. Replace AN/ARC-51BX receiver-transmitter. b. Replace AN/ARC-51BX control panel. c. Replace audio control panel. d. Replace defective cable.
No facility transmit output,	a. Transmitter in facility is defective. b. Uhf antenna is defective c. Cable is defective . . .	a. Replace AN/ARC-51BX receiver-transmitter. b. Replace uhf antenna. c. Replace defective cable.
Operating frequency is incorrect.	a. Receiver-transmitter is defective. b. Control panel is defective c. Cable is defective . . . . .	a. Replace AN/ARC-51 BX receiver-transmitter. b. Replace AN/ AR C-51BX control panel. c. Replace defective cable.
One operator is unable to transmit,	a. Respective transmit switch is defective. b. Respective audio control panel is defective.	a. Replace defective switch, b. Replace defective audio control panel.
Improper squelch operation.	a. Receiver-transmitter is defective. b. Control panel is defective	a. Replace AN/ARC-51BX receiver-transmitter. b. Replace AN/A RC-51BX control panel.

**3-10. Troubleshooting Vhf Command Facility**

F a u l t	Probable cause	SOLUTION
No facility audio output	a. Receiver in facility is defective b. Audio control panel is defective	a. Replace Radio Set AN/ARC-115. b. Replace audio control panel.
No facility transmit output	a. Transmitter in facility is defective b. Vhf antenna is defective c. Defective antenna cable cf. Defective Audio Threshold System	a. Replace Radio Set AN/ARC-115, b. Replace vhf antenna, c. Repair or replace antenna cable. d. Replace Audio Threshold System.
Operating frequency is incorrect One operator is unable to transmit	Defective radio a. Respective transmit switch is defective . . . . . b. Operator's audio control panel is defective . . . . . c. Defective Audio Threshold System	Replace Radio Set AN/ARC-115, a. Replace defective switch. b. Replace operator's audio control panel. c. Replace Audio Threshold System.
Improper squelch operation	Defective radio.....	Replace Radio Set AN/ARC-115.

**3-11. Troubleshooting Automatic Direction Finder**

F a u l t	Probable cause	Solution
Nv audio output.	a. Adf receiver is defective b. Audio control panel is defective c. Defective wiring	a. Replace adf receiver. b. Replace audio control panel, c. Repair or replace wiring,

**3-11. Troubleshooting Automatic Direction Finder — Continued**

Fault	Probable cause	Solution
Operating frequency is incorrect.	a. Defective receiver.....	a. Replace adf receiver.
Direction finding indicator does not point to station.	b. Defective adf control.....	b. Replace adf control.
	a. Defective adf receiver.....	a. Replace adf receiver.
	b. Defective adf loop antenna.....	b. Replace adf loop antenna.
	c. Defective heading-radio bearing indicator.	c. Replace heading-radio bearing indicator.
	d. Defective impedance-matching amplifier	d. Replace impedance-matching amplifier.
	e. Defective wiring.....	e. Repair or replace wiring.
Adf nulls in two directions . . . . .	a. Defective impedance-matching amplifier.	a. Replace impedance-matching amplifier.
	b. Defective receiver.....	b. Replace adf receiver.
	c. Defective sense antenna.....	c. Replace sense antenna.
All functions inoperative	a. Defective adf receiver.....	a. Replace adf receiver.
	b. No. 28-vdc power.....	b. Replace circuit breaker.
	c. Defective wiring.....	c. R8Pair or replace wiring.
Indicator does not rotate when Loop L-R control is moved and LOOP mode is selected.	a. Defective adf receiver	a. Replace adf receiver.
	b. Defective LOOP L-R switch . . . . .	b. Replace adf control.
	c. Defective heading-radio bearing indicator.	c. Defective heading-radio bearing indicator.
	d. Defective wiring.	d. Replace or repair wiring.
No BFO tone in CW position in ANT or LOOP modes,	a. Defective adf receiver.	a. Replace adf receiver.
	b. Defective adf control.	b. Replace adf control.
	c. Defective wiring.	c. Repair or replace wiring.
No signal received in ANT mode.	a. Defective sense antenna cable.	a. Repair or replace sense antenna cable.

**3-12. Troubleshooting Proximity Warning Facility (YG-1054)**

Fault	Probable cause	Solution
No audio output when in range of similarly equipped aircraft with equipment operating.	a. Proximity warning receiver/transponder is defective.	a. Replace proximity warning receiver/transponder.
	b. Audio control panel is defective.	b. Replace audio control panel.
	c. Defective wiring.	c. Repair or replace wiring.
Receiver-transponder power on lamp does not light.	a. Panel lamp loose in socket or defective.	a. Check panel lamps for proper seating and replace if necessary.
	b. Circuit breaker defective.	b. Replace circuit breaker.
	c. Interconnection wiring to circuit breaker defective.	c. Repair defective wiring.
NOTE		
The ABOVE, EQUAL and BELOW lamps normally light and cycle one time when power is initially applied.		
Receiver-transponder ABOVE, EQUAL and BELOW lamps do not light when CONFIDENCE TEST switch is ON.	a. Panel lamps defective.	a. Replace panel lamps.
	b. Receiver-transponder defective.	b. Replace receiver-transponder.

**3-13. Troubleshooting Gyromagnetic Compass Set**

Fault	Probable cause	Solution
Magnetic compass does not work.	a. Heading-radio bearing indicator is defective.	a. Replace heading-radio bearing indicator.
	b. Compass transmitter is defective.	b. Replace compass transmitter.
	c. Directional gyro is defective.	c. Replace defective cylinder.
	d. Defective wiring.	d. Repair or replace wiring.
Magnetic compass mode indication is incorrect,	Compass set needs adjustment.	Adjust in accordance with instructions in TM 11-6605-202-12 and section III of this manual.
Slaved gyro mode does not work.	Directional gyro is defective.	Replace directional gyro.
Inoperative and power failure flag not visible.	a. Defective directional gyro.	a. Replace directional gyro.
	b. Defective circuit breaker.	b. Replace circuit breaker.
Compass card does not rotate or annunciator moves incorrectly.	a. Defective heading-radio bearing indicator.	a. Replace heading-radio bearing indicator.

**3-13. Troubleshooting Gyromagnetic Compass Set—Continued**

Fault	Probable cause	Solution
Compass slaves at wrong rate (should be 1.5 to 3.5 degrees per minute).	b. Defective directional gyro.	b. Replace directional gyro.
	c. Defective wiring.	c. Repair or replace wiring.
	Defective directional gyro.	Replace directional gyro.
Free gyro drift rate exceeds 5.5 degrees per hour.	Defective directional gyro.	Replace directional gyro.
Magnetic compass mode does not work.	a. Heading-radio bearing indicator is defective.	a. Replace heading-radio bearing indicator.
	b. Compass transmitter is defective.	b. Replace compass transmitter.
	c. Directional gyro is defective.	c. Replace defective cylinder.
Magnetic compass mode indication is incorrect.	Compass set needs adjustment.	Adjust in accordance with instructions in TM 11-6605-202-12 and section III of this manual.
	Directional gyro is defective.	Replace directional gyro.

**3-14. Troubleshooting the Transponder**

Fault	Probable cause	Solution
Transponder does not respond to interrogation.	Defective transponder radio.	Replace transponder radio.
Transponder responds with wrong code.	a. Defective transponder control.	a. Replace transponder control.
	b. Defective transponder radio.	b. Replace transponder radio.
No audio output.	a. Defective audio control panel.	a. Replace audio control panel.
	b. Defective transponder radio.	b. Replace transponder radio.

**3-14.1. Troubleshooting the Radar Warning System, AN/APR-39**

(fig. 3-18)

**NOTE**

Direct support and general support maintenance procedures of the AN/APR-39 are in (C) TM 11-5841-283-34 which is a classified manual, therefore, troubleshooting of the radar warning facility components will not be covered in this chapter.

boards are given in the subparagraphs that follow. The charts list the function of the circuit on each terminal. Audio and lighting voltages are only indicated categorically since their value changes with control settings. All equipment is on for voltage measurements.

**NOTE**

Proximity warning facility provisions are made after MWO 55-1520-228-30/22 and change 1 which achieves dual frequency communications capability, has been applied.

**3-15. Terminal Board Voltage Measurements**

Charts of voltages on the avionics associated terminal

a. TB6, PANEL LIGHTS.

Terminal	Facility	Function	voltage
A1	Uhf command	Panel light	Up to 28 dc
A2	Audio control panel, pilot's	Panel light	Up to 28 dc
B1	Vhf command	Panel light	Up to 28 dc
C1	No, 2 fm	Panel light	Up to 28 dc
D1	No, 1 fm	Panel light	Up to 28 dc
D2	Automatic direction finder	Panel light	Up to 28 dc
A3	Audio control panel, copilot's	Panel light	Up to 28 dc
A5	Audio control panel, pilot's	Panel light	Up to 28 dc
B5	Audio control panel, crew's	Panel light	Up to 28 dc
B16*	Audio control panel, pilot's	Headset, high	Audio
C13*	IFF radio	Headset, high	Audio
C16*	Audio control panel, copilot's	Headset, high	Audio

\* Connections exist only when provisions for Proximity Warning Facility YG-1054 are made.

b. TB19.

Terminal	Facility	Function	Voltage
A1	Audio control panel, pilot's	Transmitter No. 1 input	Audio
A2	No. 1 fm	Input signal	Audio
B1	Audio control panel, copilot's	Transmitter No. 1 input	Audio
B2	Audio control panel, crew's	Transmitter No. 1 input	Audio
C1	Audio control panel, pilot's	Transmitter No. 5 input	Audio

Terminal	Facility	Function	voltage
C2	No. 2 fm	Input signal	Audio
D1	Audio control panel, copilot's	Transmitter No. 5 input	Audio
D2	Audio control panel, crew's	Transmitter No. 5 input	Audio
A3	Audio control panel, pilot's	Transmitter No. 3 input	Audio
A4	Vhf command	Input signal	Audio
B3	Audio control panel, copilot's	Transmitter No. 3 input	Audio
B4	Audio control panel, crew's	Transmitter No. 3 input	Audio
C3	Audio control panel, pilot's	Transmitter No. 2 input	Audio
C4	Uhf command	Input signal	Audio
D3	Audio control panel, copilot's	Transmitter No. 2 input	Audio
D4	Audio control panel, crew's	Transmitter No. 2 input	Audio
A5	Audio control panel, pilot's	Transmitter No. 1 control	Ground when transmitting
A6	No. 1 fm	Transmit control	Ground when transmitting
B5	Audio control panel, copilot's	Transmitter No. 1 control	Ground when transmitting
B6	Audio control panel, crew's	Transmitter No. 1 control	Ground when transmitting
A9	No. 1 fm	Plus 28 volts dc	+28 dc
A10	No. 1 fm	Plus 28 volts dc	+28 dc
A11	No. 2 fm	Retransmit audio output	Audio
A12	No. 1 fm	Retransmit audio input	Audio
B9	Heading-radio bearing indicator	Plus 28 volts dc	+28 dc
C11	No. 2 fm	Retransmit control output	Ground when transmitting
C12	No. 1 fm	Retransmit control input	Ground when transmitting
A13	No. 1 fm	Retransmit audio output	Audio
A14	No. 2 fm	Retransmit audio input	Audio
C13	No. 1 fm	Retransmit control output	Ground when transmitting
C14	No. 2 fm	Retransmit control input	Ground when transmitting
A15	Audio control panel, pilot's	Plus 28 volts dc	+28 dc
A16	Audio control panel, pilot's	Plus 28 volts dc	+28 dc
B16	Audio control panel, copilot's	Plus 28 volts dc	+28 dc

## c. TB20.

Terminal	Facility	Function	voltage
A1	Audio control panel, pilot's	Interphone control return	Ground
C1	Audio control panel, copilot's	Interphone control return	Ground
A3	Automatic direction finder	S1/Rotor common	Ground
A4	Heading-radio bearing indicator	Stator Z	Ground
B3	Heading-radio bearing indicator	Rotor common	Ground
C3	Audio control panel, crew's	Interphone control return	Ground
A9	Audio control panel, copilot's	Transmit control input	Ground when transmitting
A10	Audio control panel, copilot's	Transmit control at copilot's switch	Ground when transmitting
C9	Audio control panel, pilot's	Transmit control input	Ground when transmitting
D9	Audio control panel, pilot's	Transmit control at pilot's switch	Ground when transmitting
A11	Audio control panel, copilot's	Interphone control input	Ground when transmitting
B11	Audio control panel, copilot's	Interphone control at pilot's switch	Ground when transmitting
C11	Audio control panel, pilot's	Interphone control input	Ground when transmitting
D11	Audio control panel, pilot's	Interphone control at copilot's switch	Ground when transmitting

## d. TB21.

Terminal	Facility	Function	voltage
A1, B1	Audio	Shields	No reference
A2, B2	Audio control panel, pilot's	Microphone, high	Audio
C1, D1	Audio control panel, pilot's	Microphone, low	Audio
C2, D2	Audio control panel, pilot's	Headset, high	Audio
A3, B3	Audio control panel, pilot's	Ground	Ground
C6, D6	Audio	Shields	
A7, B7	Audio control panel, copilot's	Headset, high	Audio
A8, B8	Audio control panel, copilot's	Headset, low	Audio
C7, D7	Audio control panel, copilot's	Headset, high	Audio
C8, D8	Audio control panel, copilot's	Headset, low	Audio

**3-16. Terminal Board Resistance Measurements**

The following chart lists the resistance between

terminal board terminals for continuity measurement.

Connection	Condition	Resistance
TB20-A9, A10 to ground	a. No transmit buttons pushed	a. Open circuit
	b. Any copilot's transmit button pushed.	b. Short circuit
TB20-A11, B11 to ground	a. No interphone button pushed	a. Open circuit
	b. Pilot's interphone button pushed	b. Short Circuit
TB20-C11 or D11 to ground	a. No interphone button pushed	a. Open circuit
	b. Pilot's interphone button pushed	b. Short circuit
TB20-C9 or D9 to ground	a. No transmit button pushed	a. Open circuit
	b. Pilot's transmit push-button pushed	b. Short circuit

Section III. ELECTRONIC CONFIGURATION REPAIRS AND ALIGNMENT

3-17. General

(fig. 3-1)

The repair and alignment procedures in this section supplement the organizational maintenance repairs and alignments in TM 11-1520-228-20 to provide complete repair and alignment procedures for the electronic equipment configuration. Removal and replacement of several cables, the connectors, circuit breakers, relays, and the No. 2 fm antenna must be performed by direct support maintenance personnel. The removal and replacement procedures for this equipment are contained in this section. Alignment procedures to be performed after the equipments are replaced are also covered in this section.

wiring diagrams in TM 11-1520-228-20. If the wiring diagram is checked, tags are not required as the replacement cables or wiring can be rewired to conform to the wiring diagrams, but they will still be handy.

(4) Slide the insulation sleeving back and unsolder all wiring routed from outside the equipment which is connected to solder terminals on relays, terminal boards, or other components. Tag each wire or group of wires to aid in replacement.

(5) Remove the cables or wiring by first removing the attaching hardware along the cables length and disconnecting the remaining end. Save all hardware for replacement.

b. Replacement.

(1) Feed the cable through attaching hardware and install the cable and hardware into the helicopter. Be careful not to damage insulation or shielding and insure that no tags are accidentally removed from the wires.

(2) Connect all wiring with terminal ends to screw terminals on the terminal boards or other components as described on tags or by referring to the wiring diagrams in TM 11-1520-228-20.

(3) Solder the remaining wiring to solder terminals on relays, terminal boards, or other components. Install new insulation sleeving where necessary.

(4) Remove all tags from wiring.

(5) Install new lacing ties on wiring harness and bundles.

(6) Replace all attaching hard wire as required.

(7) Replace all equipment and access covers removed in a (1) of removal procedures.

**3-18. Removal and Replacement of Cables and Wiring**

a. Removal.

**NOTE**

Equipment without electrical cable connectors should not be removed unless in-place repair is not possible.

(1) Remove access covers and equipment as necessary to reach the cable or wiring to be removed (figs. 3-2 through 3-1 1).

(2) Cut the lacing ties from all wire bundles as necessary.

(3) Disconnect wiring connected to terminal boards as necessary. Tag each wire or group of wires to aid in replacement. Another technique is to check that each wire (as identified by wire number) is connected to terminals as specified in

c. Removal of Headset-Microphone Cords and Jacks.

(1) Disconnect and tag individual wires of the headset-microphone cord from the associated terminal board.

(2) Remove all clamps that secure the cord to the aircraft structure.

(3) Remove the side covers from the headset-microphone jack by removing the attaching screws.

(4) Slide the insulation sleeving back and unsolder all wiring from the jack and switch terminals.

(5) Uncrimp the band that secures the headset-microphone cord to the jack brace.

(6) Untie the nylon cord from the jack bracket and remove the jack from the headset-microphone cord.

d. Replacement of Headset-Microphone Cords and Jacks.

(1) Tie the nylon cord of the headset-microphone cord to the notched bracket in the headset-microphone jack.

(2) Crimp the metal band around the headset-microphone cord and jack brace.

(3) Slide a length of insulation sleeving over each wire end and solder the wiring to the jack switch terminals in accordance with their tags.

e. Removal of Relays. The following procedures apply only to those relays that are equipped with solder terminals.

(1) Slide the insulation sleeving back and unsolder the wires from the terminals. Tag each wire to aid in replacement.

(2) Remove the relay by removing the attaching hardware.

f. Replacement of Relays. The following procedures apply only to those relays that are equipped with solder terminals.

(1) Install the relay in place with the attaching hardware.

(2) Slide a length of insulation sleeving over each wire end and solder proper wires to the relay terminals. Remove the tags and slide the sleeving over the terminals.

g. Removal of Coaxial Cable Connectors.

(1) Remove the equipment, if applicable (TM 11-1520-228-20).

(2) Remove and tag all electrical wiring contact pins from the plug body; use the standard 16 and 20 AWG removal tools.

**CAUTION**

The coaxial cable contact assemblies must be pulled straight out without rotation. The removal tool must be perpendicular to the plug body at all times.

Failure to observe these precautions may result in damage to the center conductor of the coaxial cable.

(3) Use a coaxial cable contact removal tool to remove the coaxial cable contact assemblies from the plug body, then remove the plug.

h. Replacement of Coaxial Cable Connectors.

**NOTE**

If any of the coaxial cables have been replaced install the contact assemblies on the replacement cables before performing the following procedure.

(1) Remove the tags and install all of the electrical wiring contact pins into the body of the connector; use standard 16 and 20 AWG insertion tools.

**CAUTION**

The coaxial cable contact assemblies must be inserted straight into the plug body without rotation. The insertion tool must be perpendicular to the plug body at all times. Failure to observe these precautions may result in damage to the center conductor of the coaxial cable.

(2) Remove the tags and install the coaxial cable contact assemblies into the plug body; use the 294-128 coaxial cable contact insertion tool.

(3) Push the sealing boot on each coaxial cable into the plug grommet until the O-ring riser snaps into place. Pull slightly on the coaxial cable to insure that the contact assembly is firmly seated in the plug.

(4) Install any equipment removed in g(1) of removal procedure (TM 11-1520-228-20).

(5) Position the aft avionics compartment access panel in place, and secure the quick-disconnect fasteners.

i. Installation of Connector Coaxial Cable Contact Assemblies.

**NOTE**

The following procedure should be performed only when replacing one or more coaxial cables.

(1) Obtain a length of RG-195A/U coaxial cable cut to the proper length. (The length can be determined by measuring the cable being replaced.)

(2) Install a sealing boot and an outer ferrule on one end of the coaxial cable.

**NOTE**

Stripping cuts must be square and sharp. Do not nick the shield, dielectric, or center conductor. Twist the strands



of the center conductor together if they separate.

(3) Strip the outer insulation, shield, and dielectric.

(4) Insert the center conductor of the coaxial cable into a center contact. The center conductor must be visible through the end center conductor.

(5) Use a 294-440 gage pin crimping tool and a 294-395 adjusting wrench to set up a 294-76 crimping tool. The jaws of the crimping tool should hold the gage pin snugly at the end of the crimping stroke.

(6) Insert a 294-1015 bushing into the crimping tool. Insert the contact (installed on the coaxial cable) into the bushing until it is firmly seated.

(7) Crimp the contact onto the cable by operating the handle of the crimping tool one full stroke. Remove the contact from the tool.

(8) Flare out the end of the shield. Do not comb out the shield.

(9) Insert the center contact firmly into a contact body assembly. Guide the inner ferrule of the contact body assembly between the dielectric and the shield.

(10) Pull gently on the coaxial cable to insure that the center contact is firmly seated.

(11) Slide the outer ferrule over the shield and inner ferrule. The outer ferrule must butt firmly against the contact body assembly. The shield must not have any slack, and it should not stick out between the outer ferrule and the shoulder of the contact body assembly.

(12) Use an outer ferrule crimping tool to crimp the outer ferrule into place.

(13) Install the assembled contact assembly into the connector body.

### 3-19. Removal and Replacement of Circuit Breakers

#### CAUTION

Lethal voltages exist in the overhead console. Insure switch BAT on the overhead console is off before attempting any work in the unit.

#### a. Removal of Circuit Breakers.

(1) Loosen the five stud fasteners on one side of the overhead console and swing the unit down.

(2) Using a small soldering iron or screwdriver unsolder or disconnect, respectively, all wiring to the defective circuit breaker, as applicable.

#### NOTE

If more than one circuit breaker needs repair or there is multiple wiring, tag

each wire or group of wires to aid in replacement.

(3) Remove all attaching hardware holding the circuit breaker to the overhead console and remove the circuit breaker.

#### b. Replacement of Circuit Breakers.

#### CAUTION

Lethal voltages exist in the overhead console. Insure switch BAT on the overhead console is OFF before attempting any repair to the unit.

(1) Replace the applicable circuit breaker and attaching hardware on the overhead console.

(2) Connect or solder all wiring to the replacement circuit breaker. Install new insulation sleeving where necessary.

(3) Remove all tags from wiring.

(4) Replace the overhead console and tighten the five stud fasteners.

### 3-20. Parts Replacement

a. General. Equipment repair normally requires replacement of parts. Parts of equipment in the electronic configuration of the OH-58A helicopter can be replaced without special procedures. Instructions in this paragraph are primarily concerned with equipment not covered in an existing technical manual. Although the instructions might be familiar to the experienced repairman, they are useful for review. Included are instructions for replacement of components on impedance-matching network (a printed circuit board), repair of the equipment mounts, and general instructions on handling of transistors. When replacing parts in high-frequency circuits, note the position of the part to be removed and replace with a new one. The location of other parts or wires should not be changed. Be careful when heating parts.

#### CAUTION

The impedance-matching network uses a printed circuit board. The conductors on this board will delaminate if excessive forces or heat is used during soldering. Work quickly and gently when soldering printed circuits.

b. Impedance-Matching Network (fig. 3-12). Components can be removed from the printed circuit board after the solder on their leads is removed. The solder can be heated and removed in one of three ways: apply tinned wire-braid which will wick the puddle away, suck it away with an ear syringe-type device (if one is available), or blow it away with a low-pressure air gun or lung power.

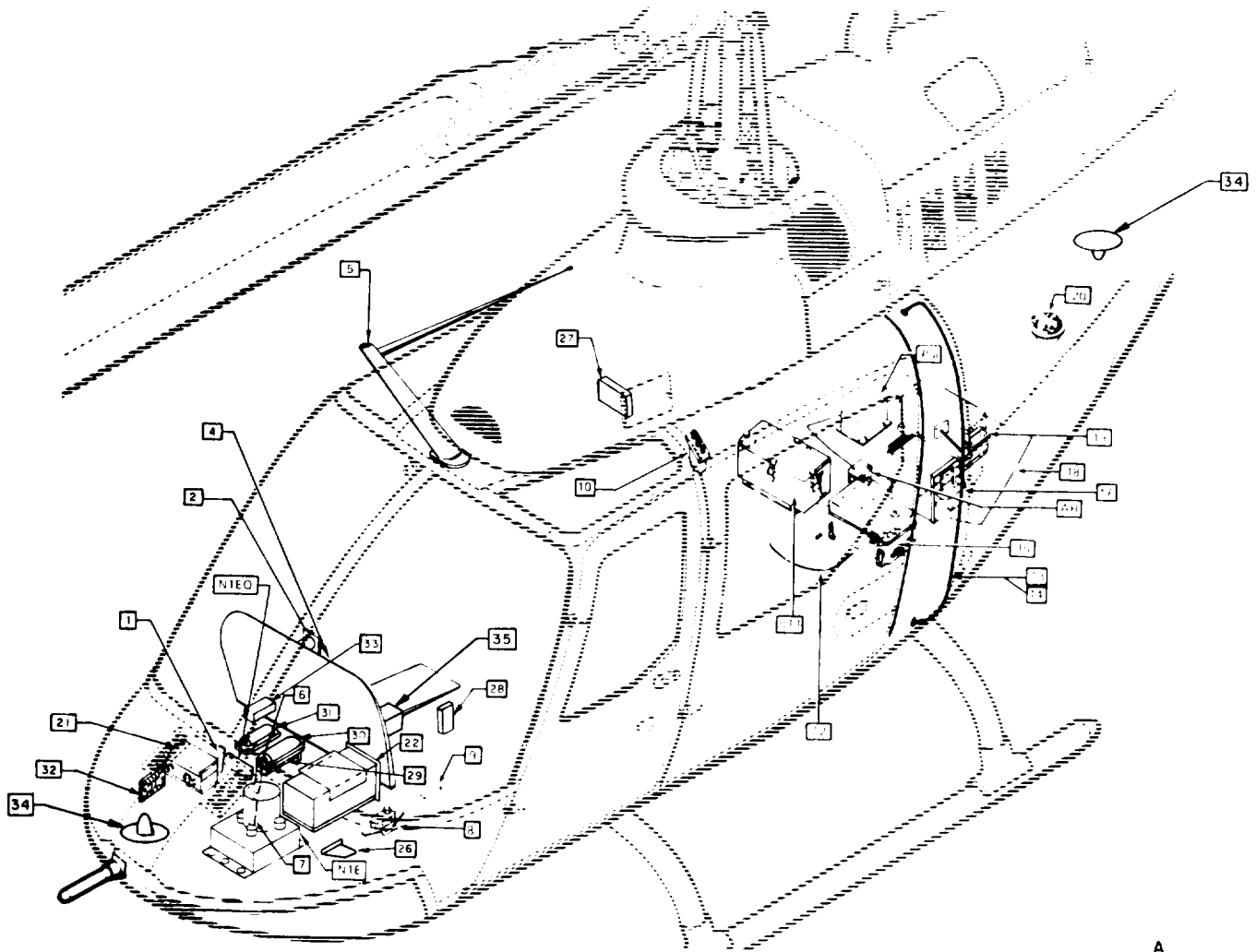

A

- 1 TERMINAL STRIP TB19
- 2 STANDBY COMPASS  
NIEQ IMPEDANCE MATCHING NETWORK
- 4 INSTRUMENT PANEL AND CONSOLE  
(SEE FIGURE 1-3  
TM 11-1520-228-20).
- 5 FM ANTENNA NO 2
- 6 TERMINAL STRIP TB20
- 7 TERMINAL STRIP TB1
- 8 TRANSPONDER ANTENNA AT-884  
( )/APX-44
- 9 TERMINAL STRIP TB4
- 10 EXTERNAL POWER CONNECTOR (P16)  
BT1 BATTERY
- 12 ADF LOOP ANTENNA As-210B/ARN-89
- 13,14 HOMING ANTENNA, LEFT AND RIGHT
- 15 ADF RECEIVER R-1496/ARB-89
- AR IMPEDANCE MATCHING AMPLIFIER  
AM-4859/ARN-B9
- 17 SECURE-VOICE ENCODER/DECODER  
TSEC/KY-28
- 18 ADF SENSE ANTENNA

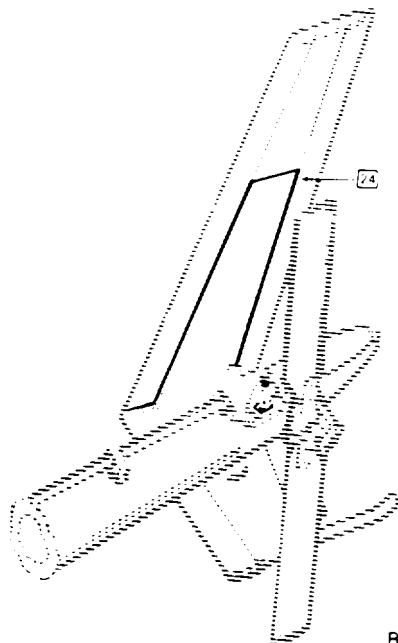

B

- 19 TRANSPONDER COMPUTER KIT-1A/  
TSEC
- 20 COMPASS TRANSMITTER T-611/ASN
- 21 TRANSPONDER TEST SET TS-1843  
APX-72
- 22 TRANSPONDER RADIO RT-859/APX-72  
PSI INVERTER
- 24 VHF/FM ANTENNA
- NIE DIRECTION GYRO
- 26 UHF ANTENNA
- 27 CREWMAN'S AUDIO CONTROL PANEL  
C6533/ARC
- 28 F ILTER (FM NO 2) FL 4
- 29 FILTER (UHF) FL 3
- 30 FILTER (VHF) FL 2
- 31 FILTER (FM NO 1) FL 1
- 32 CAPACITOR BOARD
- 33 AUDIO THRESHOLD SYSTEM  
266-075-597
- 34 PROXIMITY WARNING SYSTEM ANTENNAS
- 35 PROXIMITY WARNING RECEIVER-  
TRANSPONDER

Figure 3-1. OH-58A helicopter equipment location.

ELOBX025

**WARNING**

Excessive pressure or careless handling can cause injury from flying molten solder. Wear eye protection and use discretion when blowing off solder. To replace parts on the printed circuit board, bend their leads to fit and insert. (Note polarity of diodes, when replacing them.) Solder the leads on both sides (if paths exist on both sides of the board). Repair breaks in the copper paths by soldering across the break.

**CAUTION**

Be careful not to get solder between isolated paths on the board, as this will cause short circuits.

c. **Static Inverter.** Inverter repair is limited to connector replacement. If inverter is determined defective, replace with a like serviceable item and

forward to depot for overhaul.

(1) Remove inverter from helicopter (TM 11-1520-228-20).

(2) Remove 13 cover attachments screws and remove cover.

(3) Remove five screws that hold printed circuit board and cautiously lift clear of mounting being careful not to damage wires or components on board.

(4) Unsolder diodes from standoff insulators attached to connector mounting screws.

(5) Remove four connector mounting screws and carefully pull connector free of mounting far enough to expose wiring.

(6) Unsolder wires from connector pins and remove connector. Identify wires for reinstallation.

**NOTE**

Replacement of inverter connector is ac-

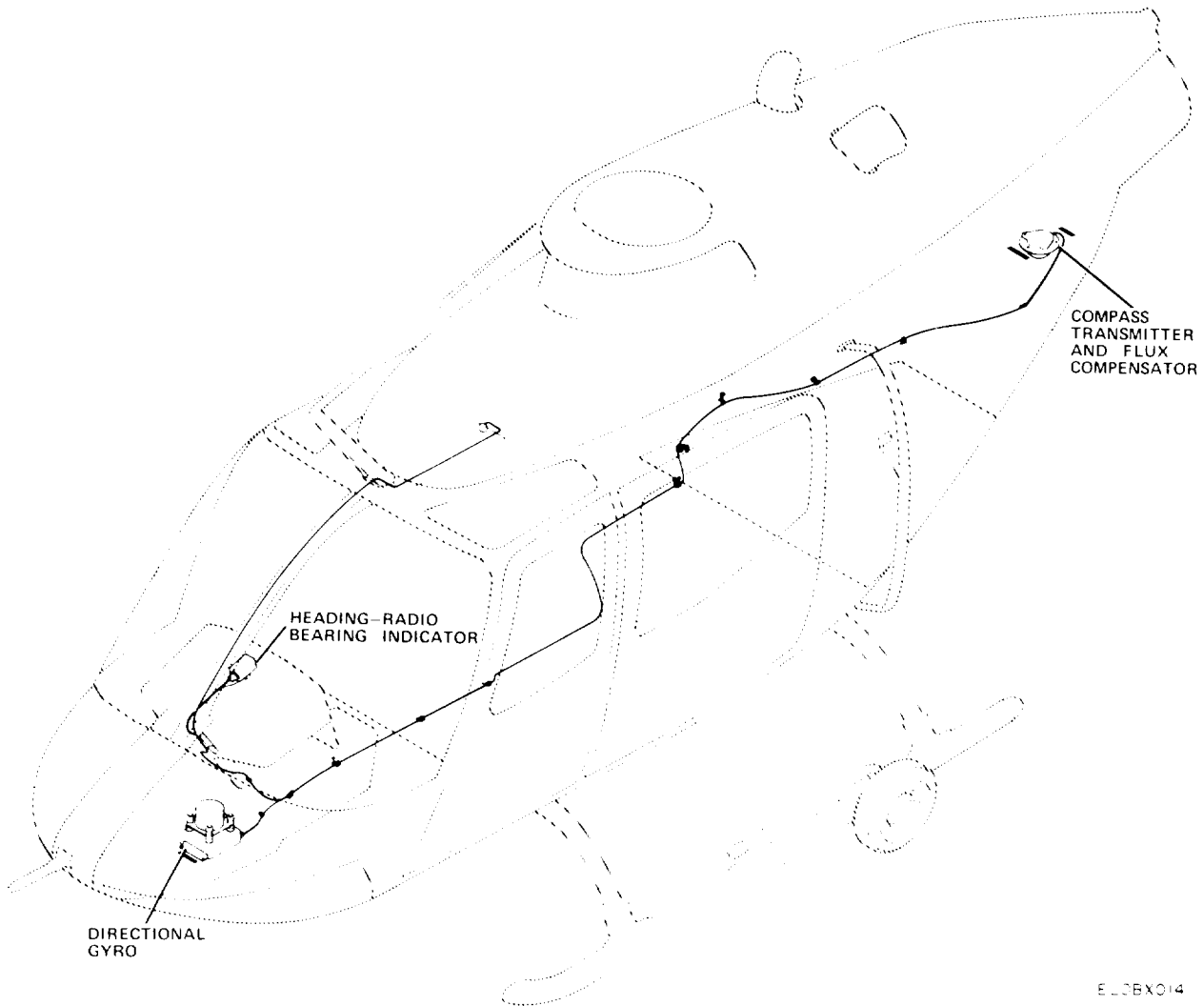

Figure 3-2. Gyro installation.

ELOBX014

ELOBX015

completed by reversing the above procedures.

d. Mounts MT-3809/APX-72, MT-3948/APX-72 and MT-3802/ARC. Repair of vibration mounts includes tightening loose screws, straightening bent trays, and replacing broken isolators. Isolators should be replaced when any sign of deterioration, such as tears or cracking appears. The isolators are replaced by removing the retaining screw and attaching a new isolator in the same place with the same screw.

e. Transistors. Transistors are relatively rugged; however they can be destroyed through careless treatment. Observance of the instructions that follow will minimize destruction of transistors during equipment repair.

- (1) Do not drop transistors onto hard surfaces.
  - (2) To protect the transistor from shock, do not cut off leads without holding the transistor firmly.
  - (3) When soldering a lead, protect the transistor from heat by gripping the lead with pliers between the soldering iron and the transistor.
  - (4) Do not attempt to check transistors with an ohmmeter set to RX 1 range.
  - (5) Avoid bending the leads close to the seal.
- f. Capacitor Board (fig. 3-13). Use normal shop practices to remove capacitors or resistor from capacitor board.

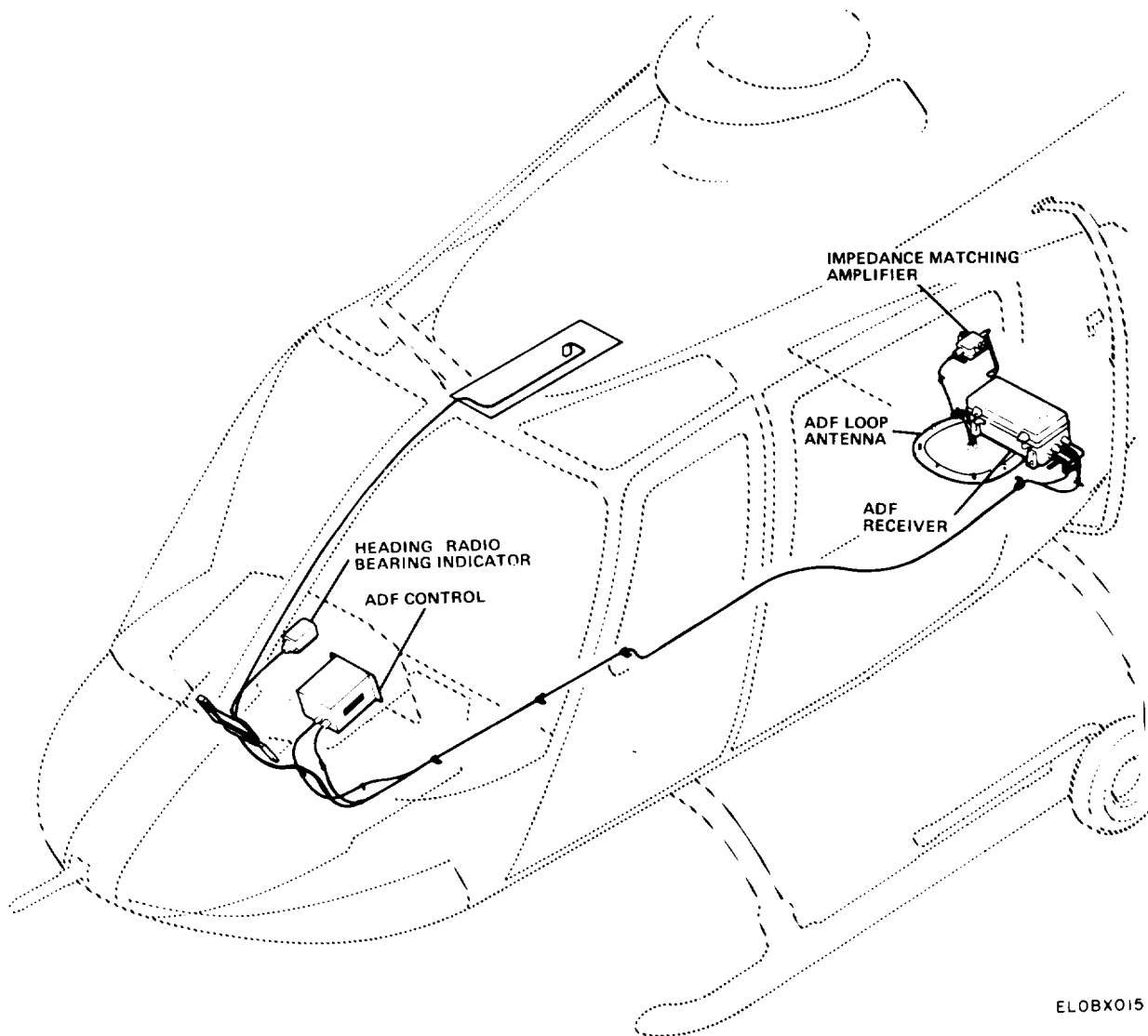

Figure 3-3. Adf installation.

**3-21. Alignment Procedures**

When compass-facility or automatic-direction-finder-facility components are replaced or known to be out of alignment, the procedures in paragraphs 3-22 and 3-23 must be performed.

**3-22. Compass Facility Alignment**

a. Secure all magnetic equipment aboard the helicopter into normal flight position. Place all circuit breakers and controls in normal flight position.

b. Position the helicopter on a compass rose away from any abnormal magnetic fields such as cars, buildings, and electrical equipment. No magnetic tools, jacks, or handling equipment can be used during alignment, and operators must not carry any magnetic material, such as watches,

keys, safety shoes, and flashlights.

c. Energize the compass facility and let it warm up for 10 minutes. The slaving switch should be set to the MAG position.

d. Set the flux compensator adjusting screws (N-S and E-W) to align their dots with the dots on the flux compensator case.

e. Loosen the compass transmitter mounting screws and align the transmitter with the helicopter's fore/aft axis.

f. Slowly rotate the helicopter at least one full turn while watching the heading-radio bearing indicator. The indicator motion should be smooth and should approximate the heading of the helicopter.

g. Point the helicopter on an east magnetic heading. Note the heading shown on the heading-

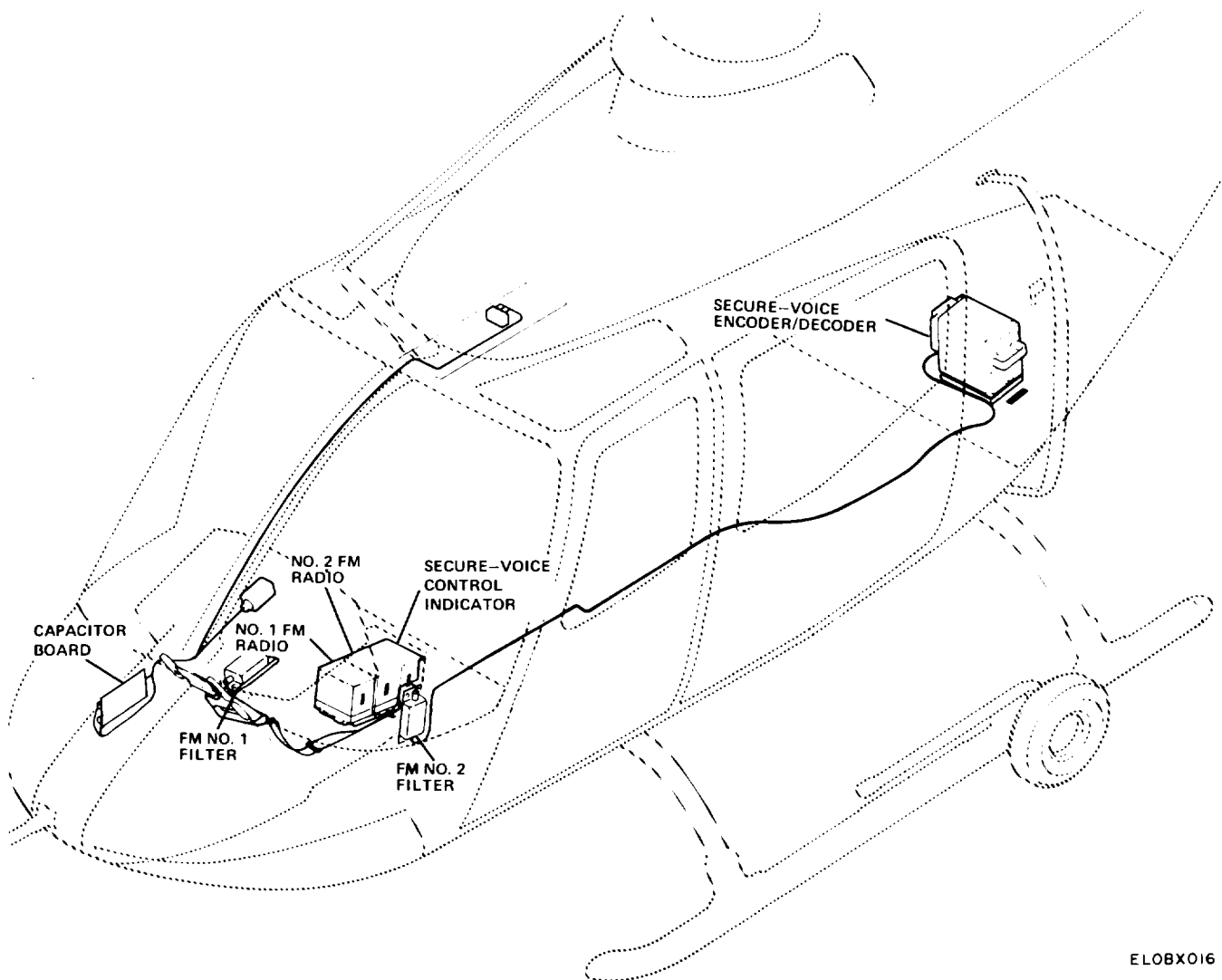

Figure 3-4. Fm installation.

radio bearing indicator and determine the deviation.

h. Repeat g for south, west, and north magnetic headings.

i. Calculate the average of the four deviations.

j. Rotate the compass transmitter the number of degrees and in the opposite direction to that of the average deviation. For example, if the average deviation was minus 6 degrees, the compass would be rotated 6 degrees positive.

k. Repeat g through j above to achieve maximum accuracy. Tighten the compass transmitter mounting screws and note the heading measurements for reference.

L Point the helicopter on a north magnetic heading.

m. Subtract the south deviation from the north deviation (determined from notes made in k

above) and divide the result by 2.

n. Adjust the N-S flux compensator screw so that the indication on the heading-radio bearing indicator moves by the amount and in the direction calculated in step m. For example, if the heading was 358 degrees and the calculation in m above was plus 1.5 degree, the N-S screw would be adjusted for a heading of 359.5 degrees.

o. Repeat n above with the helicopter pointing on a south magnetic heading.

p. Point the helicopter on an east magnetic heading.

q. Subtract the west deviation from the east deviation (determined from notes made in k above) and divide the result by 2.

r. Adjust the E-W flux compensator screw so that the indication on the heading-radio bearing indicator moves by the amount and in the direc-

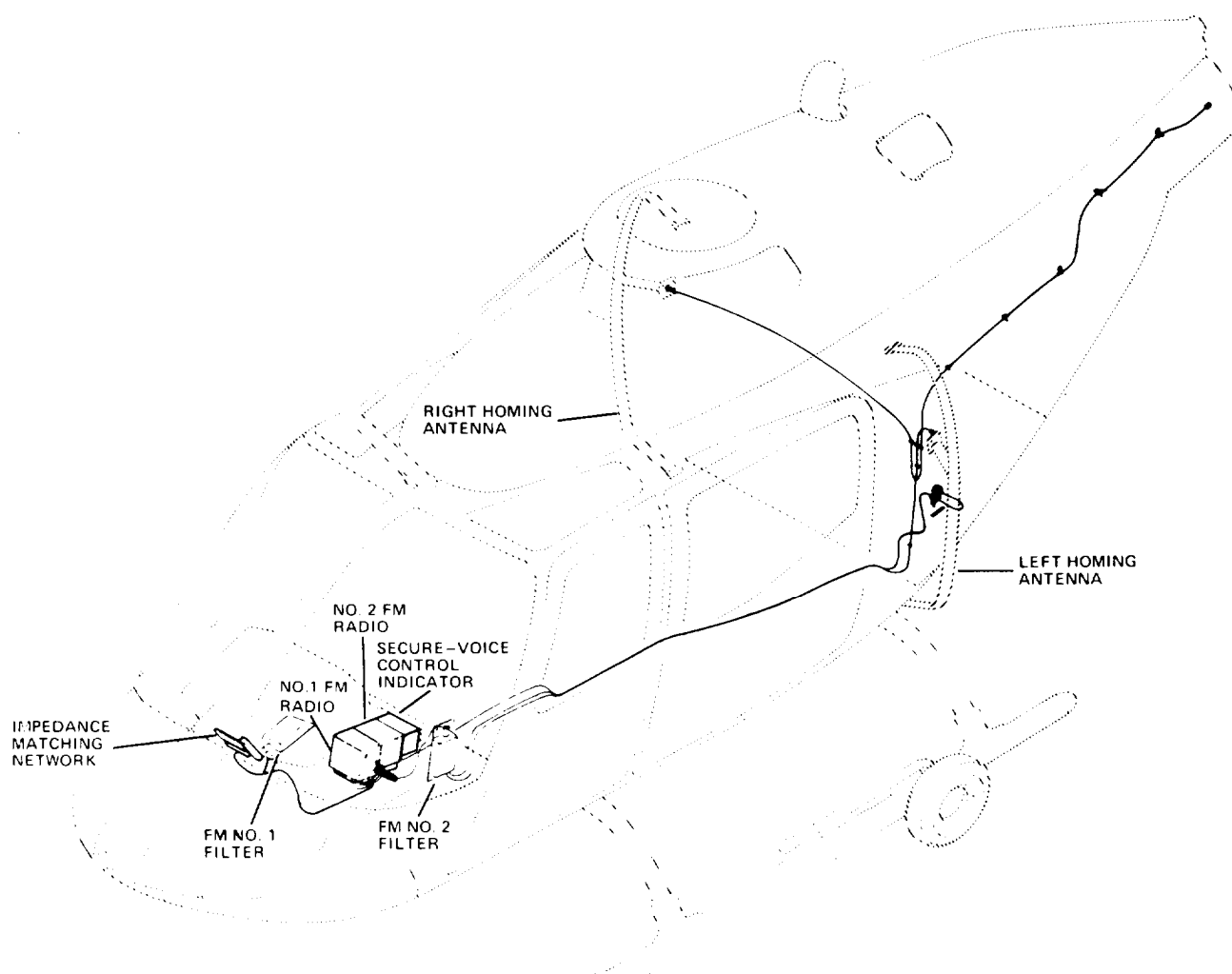

ELOBX017

Figure 3-5. Fm antenna installation.

tion calculated in *q* above. For example, if the heading was 90 degrees and the calculation in *q* above was plus 0.75 degree, the E-W screw would be adjusted for the heading of 89.75 degrees.

s. Repeat r above with the helicopter pointing on a west magnetic heading.

t. Repeat g through s above until all deviations are less than 2 degrees.

u. Make measurements of heading deviation, one at every 30-degree increment on the compass rose. Record the deviations on the compass correction card, along with the compass transmitter, flux compensator, and heading-radio bearing indicator serial numbers.

u. Seal the N-S and E-W screws with lacquer.

### 3-23. Automatic Direction Finder Facility Alignment

(fig. 3-15)

Alignment of the automatic direction finder will require execution of a through h below. Loop compensation data is provided by the manufacturer and included in this manual. Instructions in TM 11-5826-227-34 will have to be followed whenever the configuration of the helicopter changes so as to effect the adf alignment.

a. Remove the R-1496/ARN-89 adf receiver and C-7392/ARN-89 adf control from the helicopter and connect them to the MK-994( )/AR as shown in figure 3-15.

b. Apply power to the MK-994( )/AR by turn-

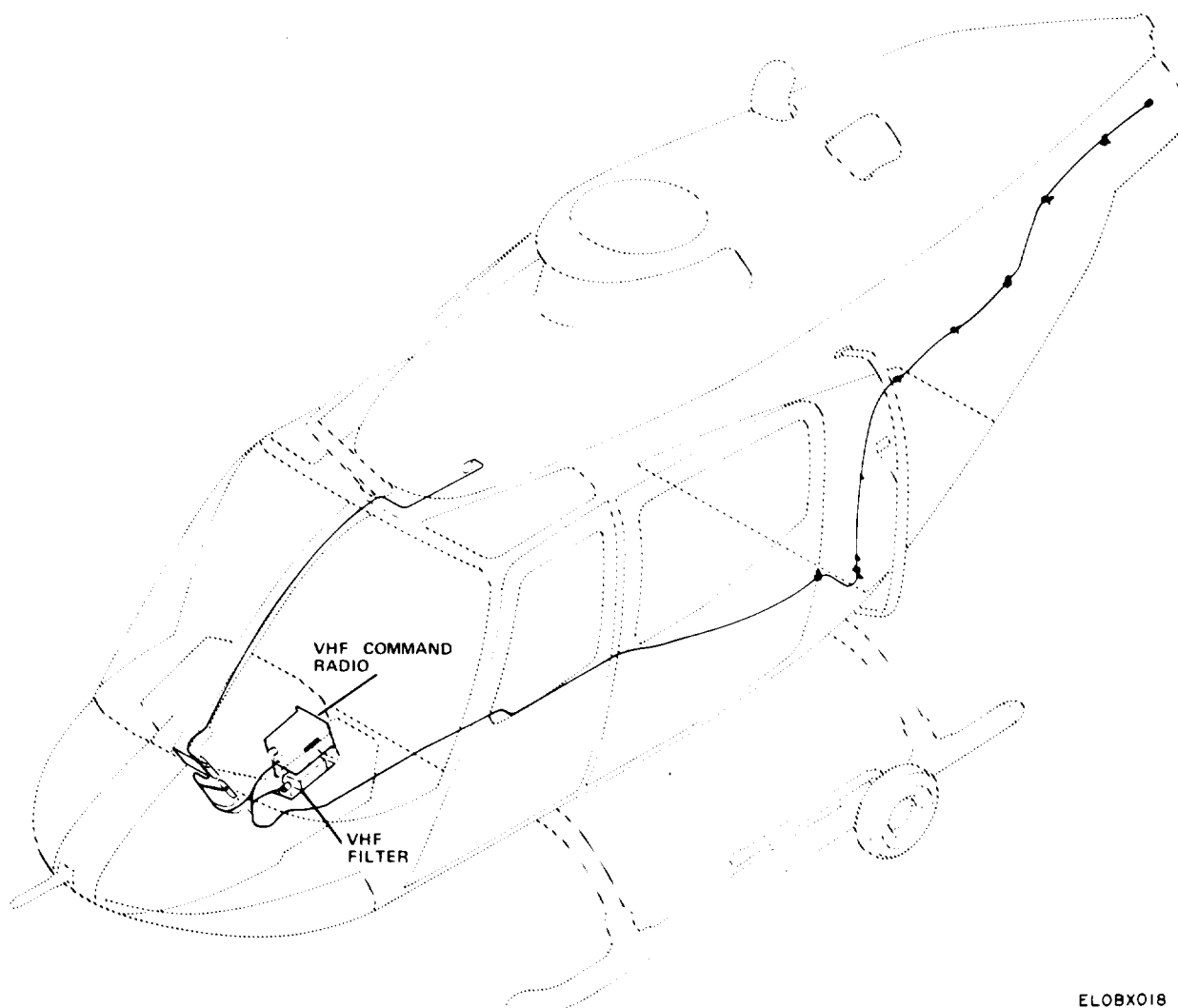

ELOBX018

Figure 3-6. Vhf installation.

- ing DC power switch to ON position.
- c. Remove the cover from the adf receiver (R-1496/ARN-89).
- d. Set the mode selector switch of the control unit to LOOP and the AUDIO control at minimum.
- e. Position the N (north) heading on the compass card under the top index marker on the ID-1351/A on the MK-994/AR.

**NOTE**

Since the loop antenna is mounted on the underside of the helicopter, *the black figures on the goniometer indicator dial shall be used.*

- f. Prior to making goniometer adjustment, rotate the 15-, 45-, and 75-degree Allen-head compensation screws counterclockwise until slight re-

sistance is felt.

- g. Position the goniometer so 45 degrees is under the hairline and observe the ID-1 351 /A indicator. The ADF needle should indicate 66 or 67. If so continue with step *h* below. If it does *not*, loosen the two Phillips-head screws at the base of the synchro-transmitter (fig. 3-16) and rotate the body of the synchro-transmitter until the ADF needle on the ID-1351/A indicates 66 degrees. Tighten the two Phillips-head screws and continue with *h* below.

**CAUTION**

In this procedure it may appear that the compensation range of a particular screw is insufficient to obtain the correct remote *indicator* reading. If this occurs, *do not force the screw* in question

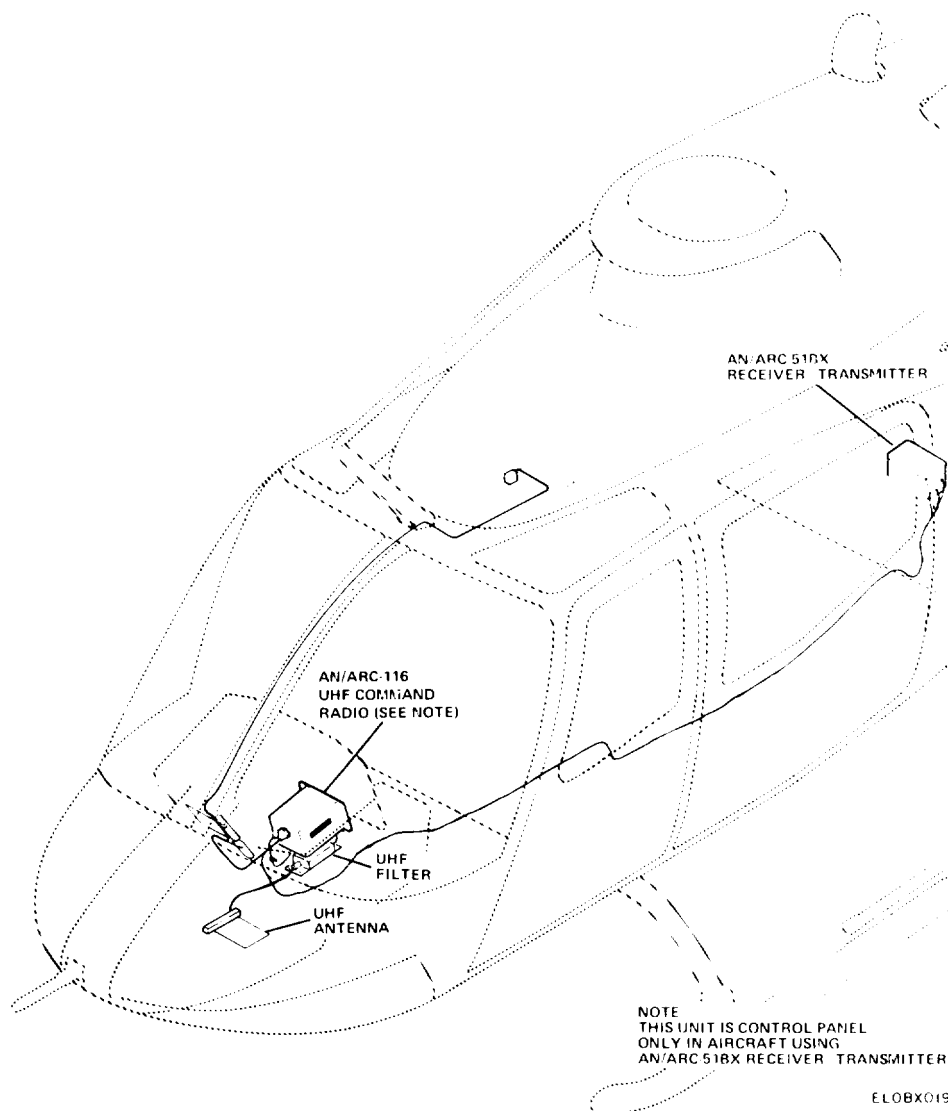

Figure 3-7. Uhf-am installation.



but continue with the remaining screws. When the compensation procedure is repeated, sufficient compensation should be available at all adjustment points.

**CAUTION**

Never turn the goniometer indicator dial by hand; system malfunction may result.

h. Rotate the goniometer drum using the LOOP L-R switch to each goniometer adjustment point (column 1 of i below) and adjust the compensation screw that the arrow points to until the ID-1351/A ADF pointer indicates the value listed in column 2 of i below. Repeat this procedure as necessary until a complete 3600 turn is made with no further adjustment required. Always approach the goniometer hairline from the

clockwise direction i.e., the goniometer dial should be rotated clockwise when placing the correct relative bearing under the hairline.,

i. Loop Compensation Data.

Goniometer Adjustment points (degrees)	Corrected Indicator reading (degrees)
Column 1	Column 2
15.....	27
45.....	65
75.....	85
105.....	103
135.....	120
165.....	160
195.....	203
225.....	238
255.....	260
285.....	277
315.....	298
345.....	340

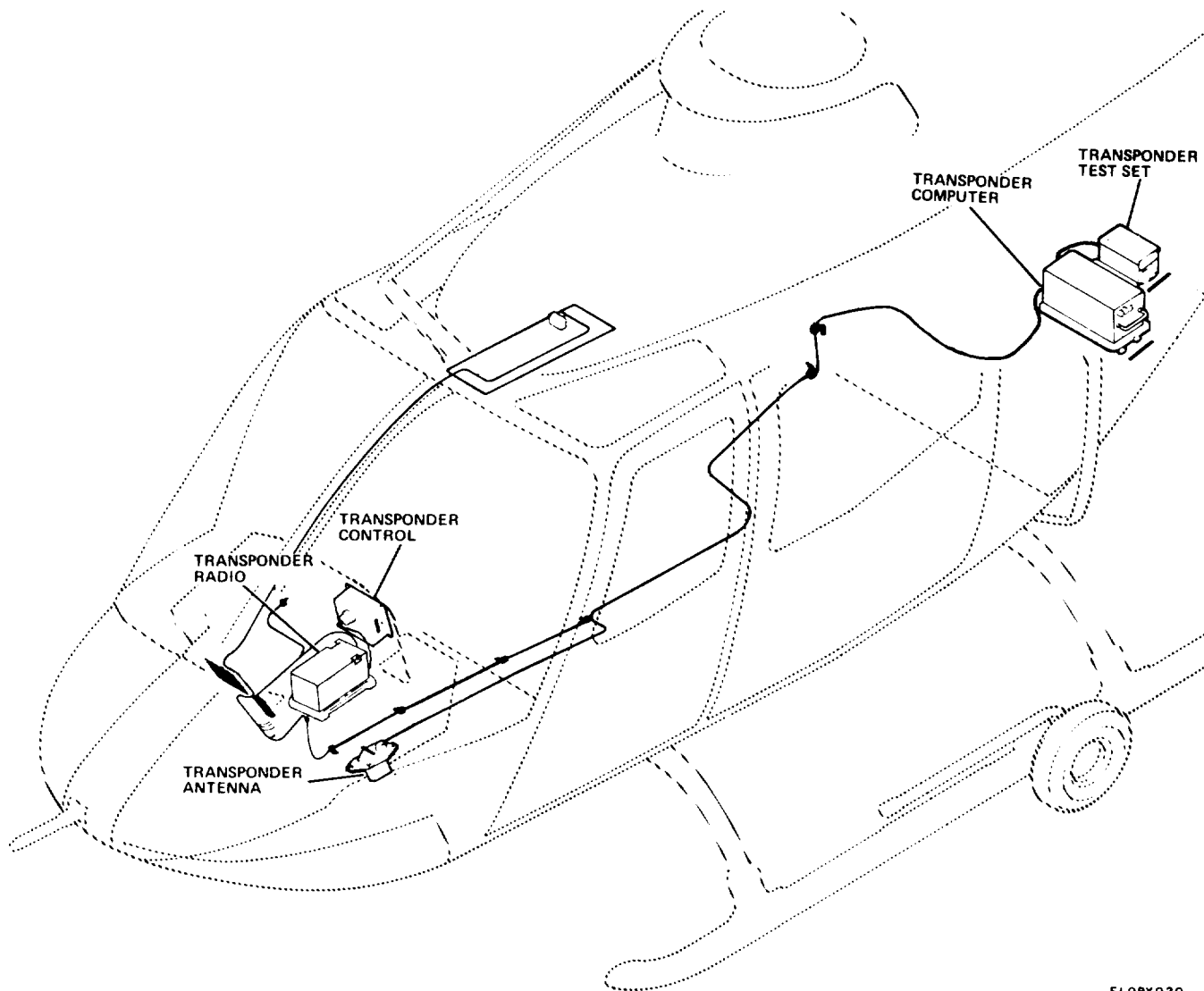

ELO8X020

Figure 3-8. Iff installation.

**NOTE**

The loop is mounted on the underside of the aircraft; therefore, the black figures on the goniometer dial shall be used.

3-24. AM-4859()/ARN-89 Amplifier, Impedance-Matching Test

**CAUTION**

Before starting the following test, turn all power to the test equipment and ADF set off. Positive 15 volts is carried on the inner conductor of the coaxial cable to the impedance-matching amplifier.

- a. Connect the equipment as shown in figure 3-17.
- b. Turn on all power, and turn impedance-matching control fully clockwise.
- c. Set COMP-ANT-LOOP selector switch to

ANT position.

- d. Set KILOCYCLES control at 365 setting.
- e. Adjust signal generator to 50-microvolt output at 1 kHz, 30 percent modulation at a frequency of 365 kHz and fine tune for maximum indication on the signal strength meter.
- f. Vary the impedance-matching control and observe that the signal strength meter fluctuates accordingly.
- g. Increase the signal generator output to 6 millivolts.
- h. Adjust the impedance-matching control until the electronic voltmeter reads 28 millivolts.
- i. Set KILOCYCLES control at 1700 setting.
- j. Set signal generator at 1700 kHz and fine tune.
- k. Note that the electronic voltmeter reads between 25 and 30 millivolts. Record the reading.
- l. Repeat *i, j, and k* above for 2950 kHz.

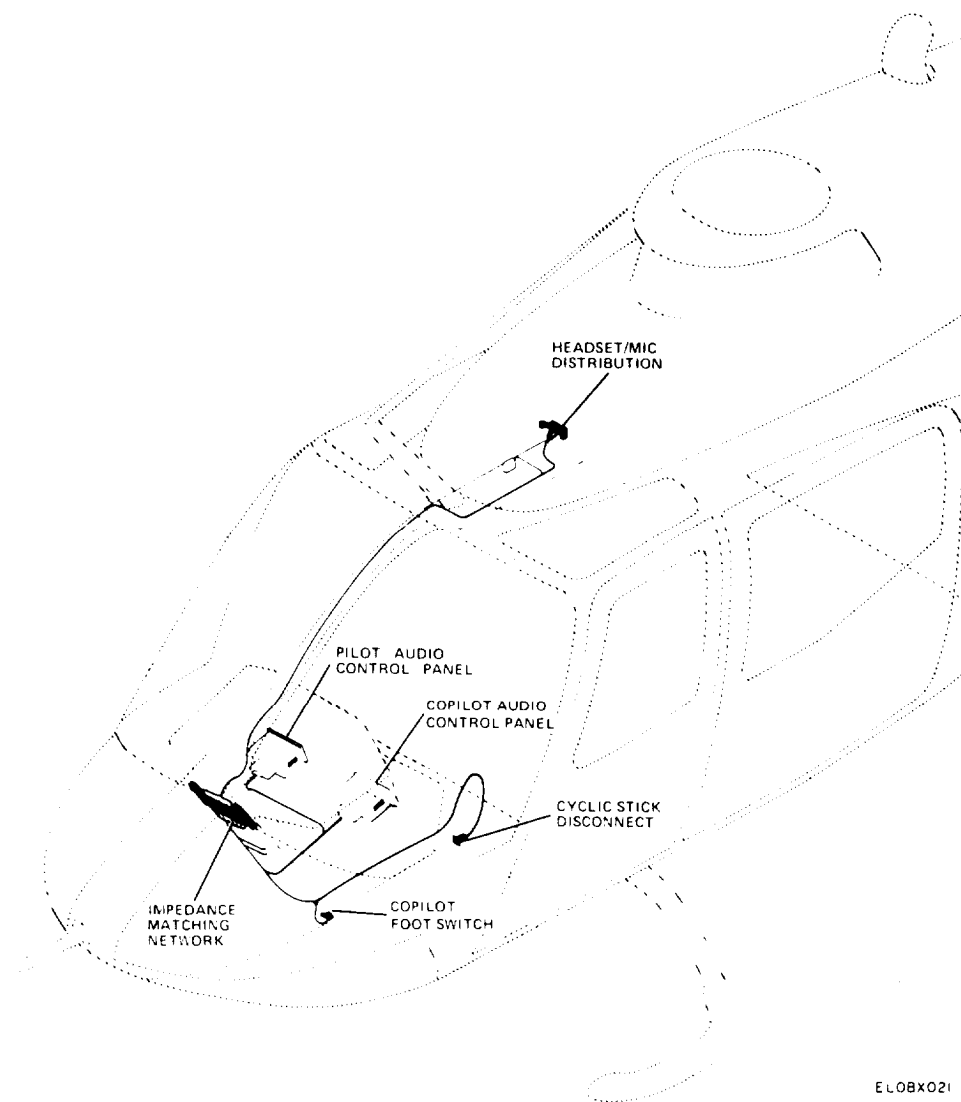

ELOBX021

Figure , 3-9. Ics installation.

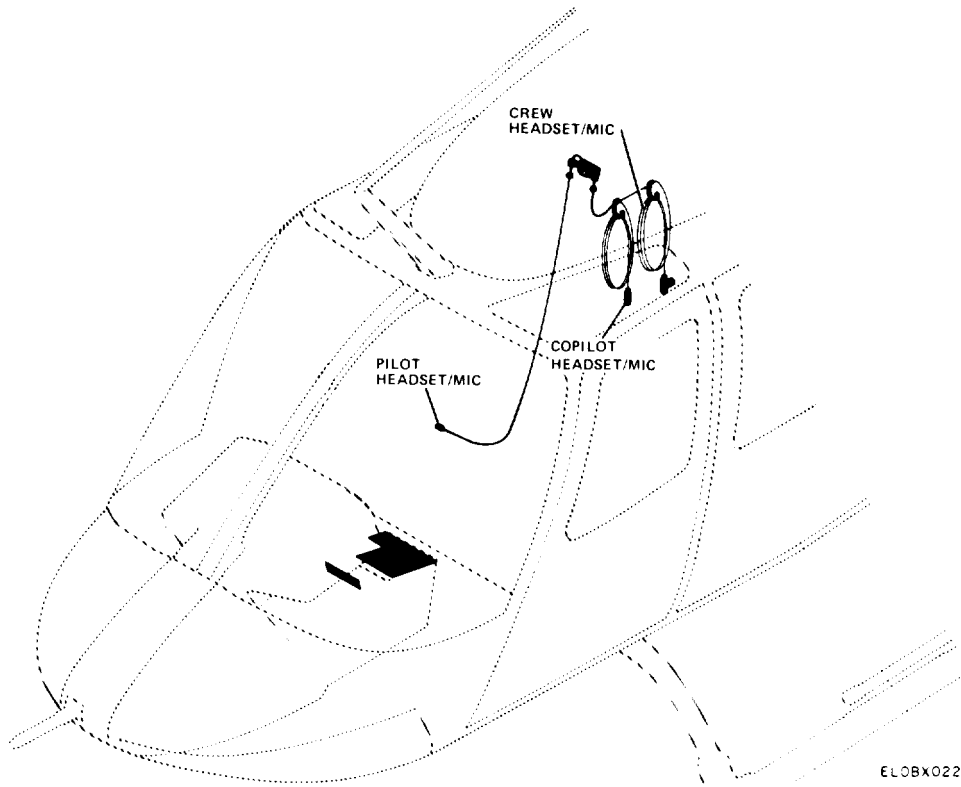

*Figure 3-10. Headset interconnect installation.*

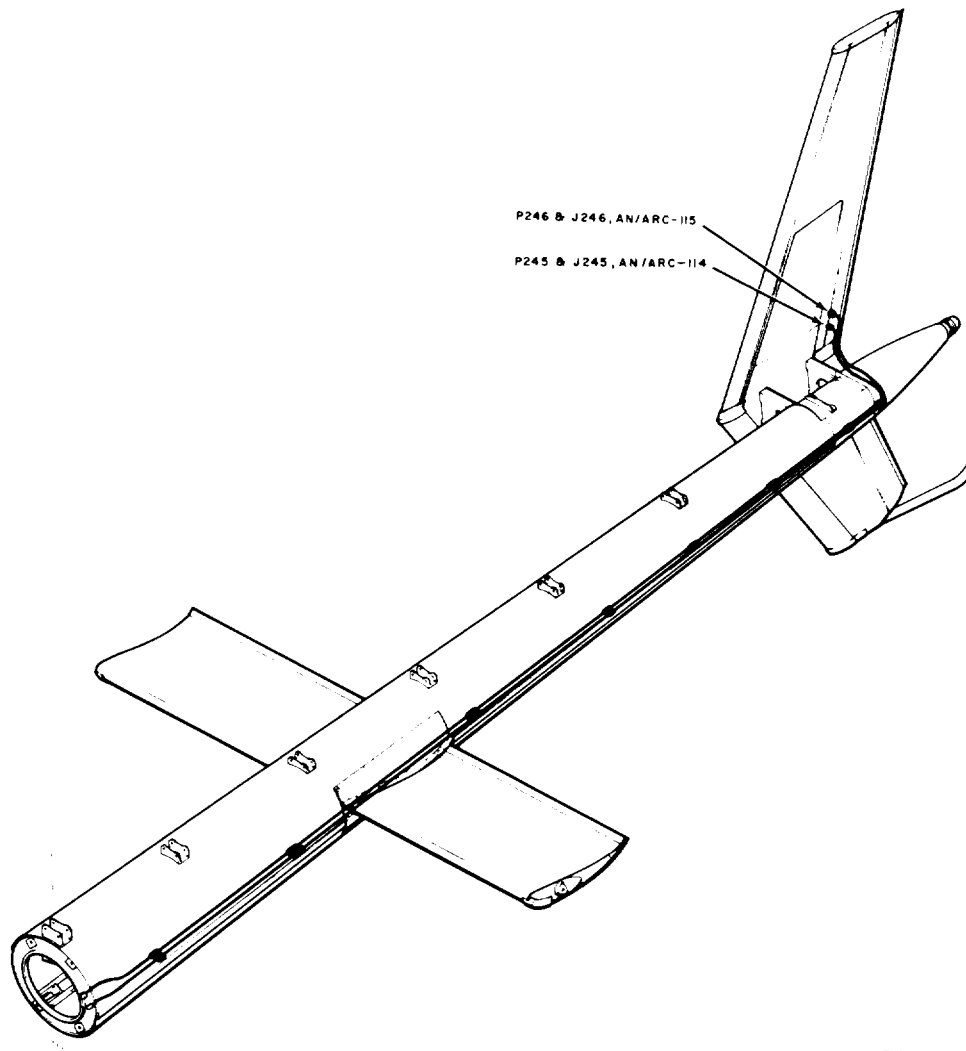

ELO#X023

Figure 3-11. Tailboom communications installation.

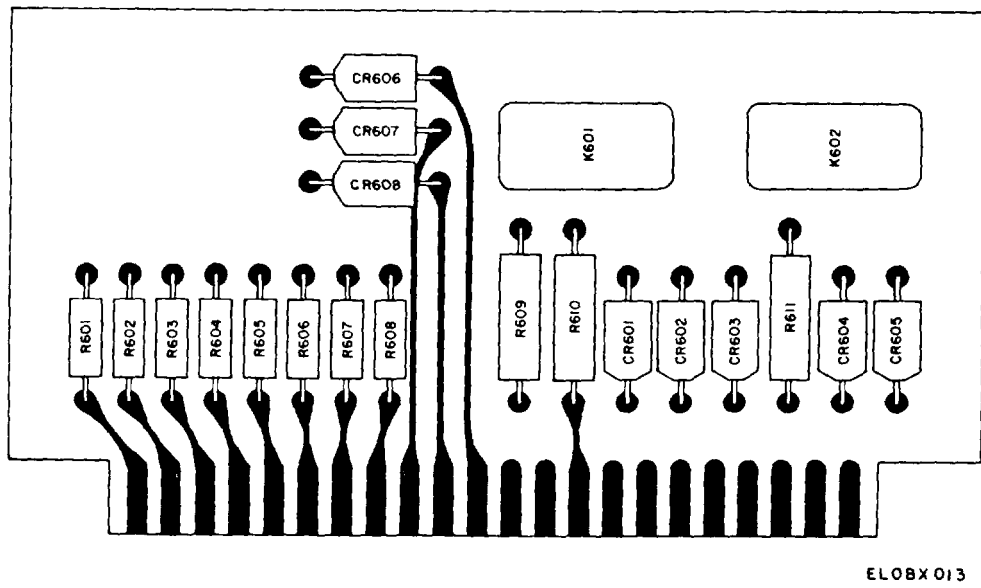

Figure 3-12. Impedance matching network, component side

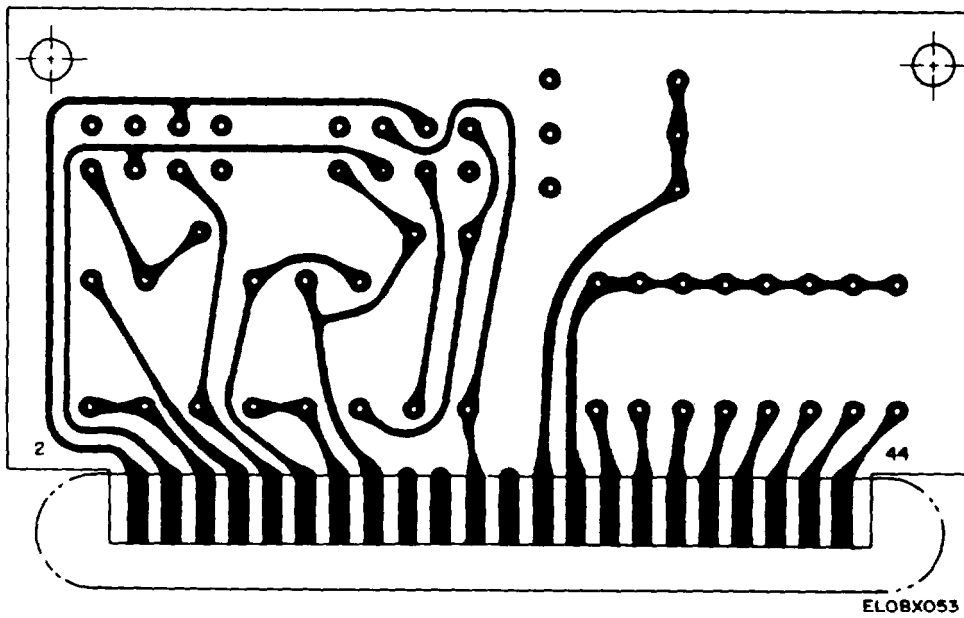

Figure 3-12. 1. Impedance matching network, foil side.

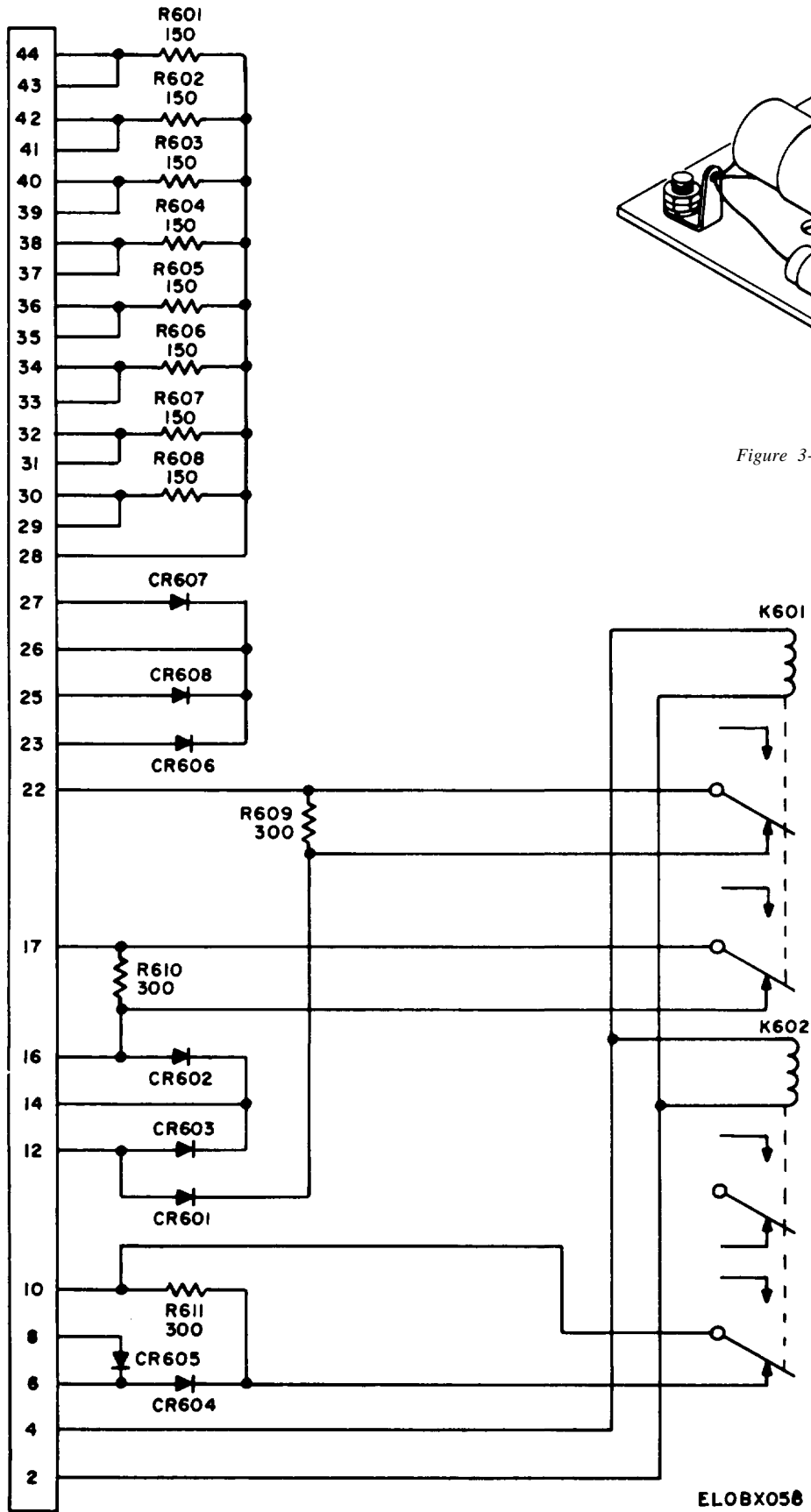

Figure 3-12.2. Impedance matching network, schematic diagram

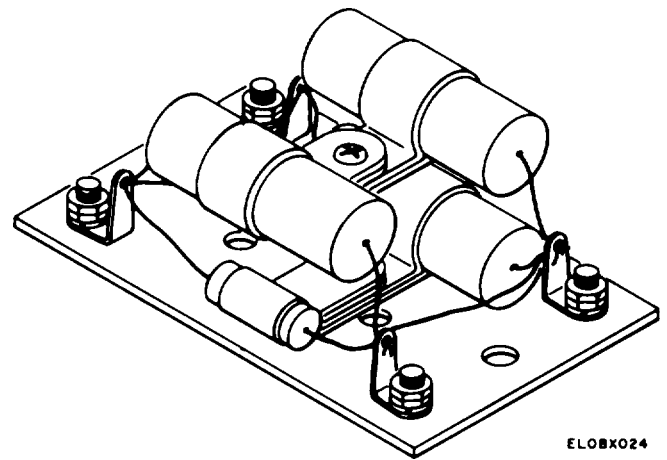

Figure 3-13. Capacitor board A3 layout

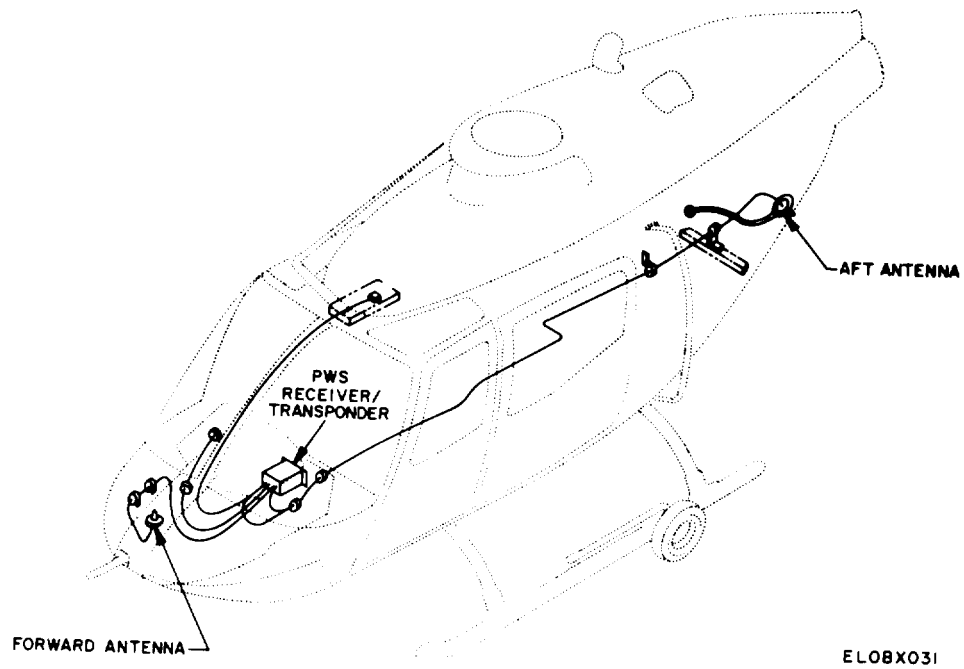

Figure 3-14. Proximity warning installation.

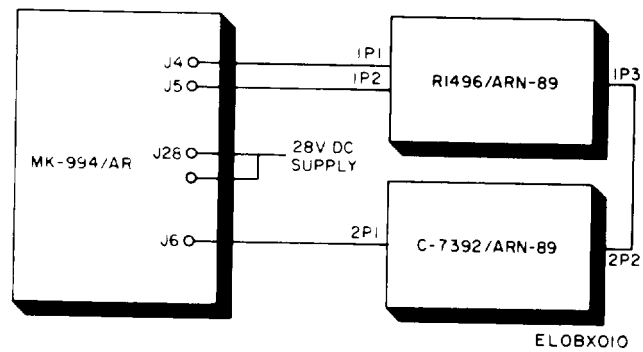

Figure 3-15. Adf facility alignment test setup.

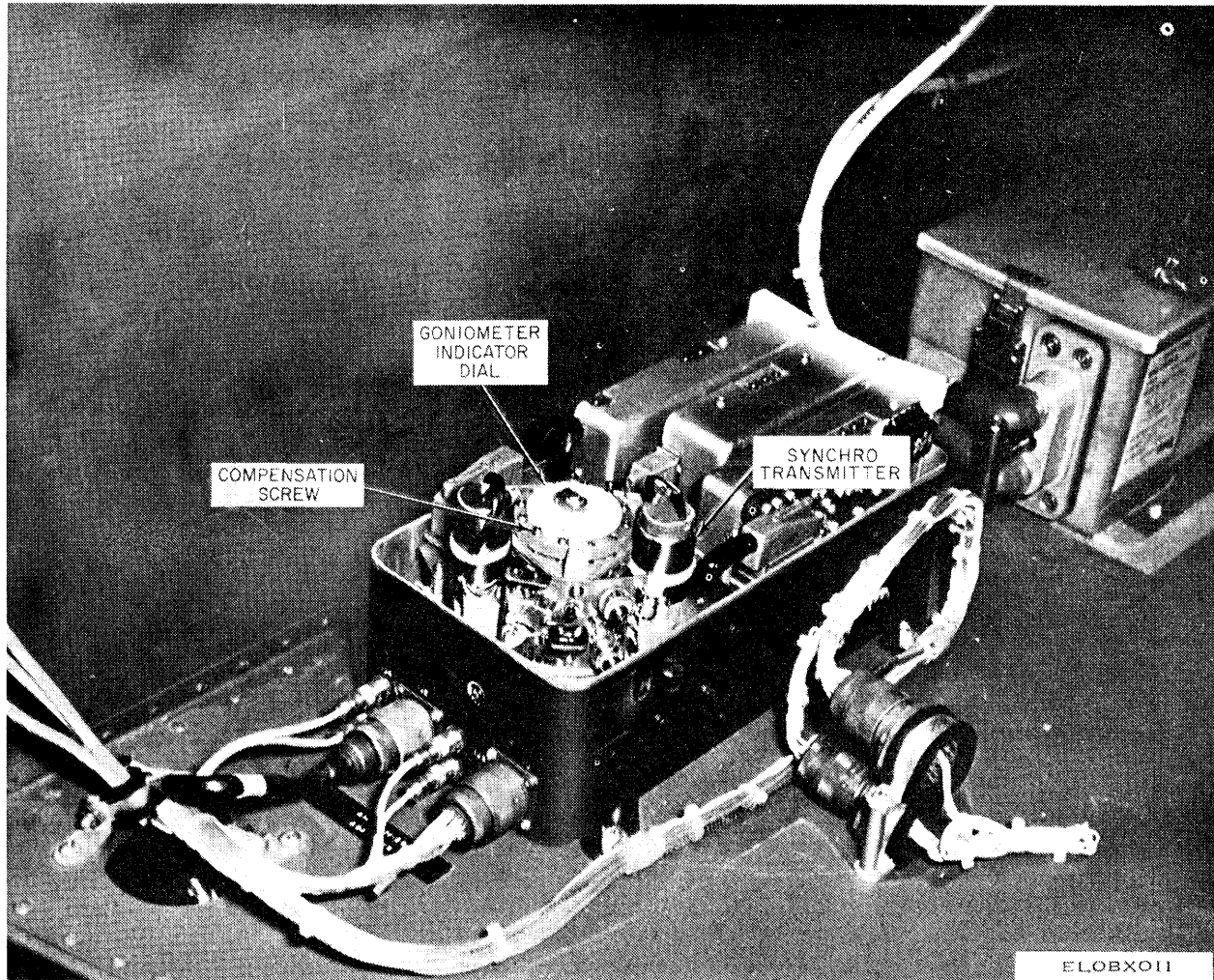

Figure 3-16. Adf receiver, cover removed.

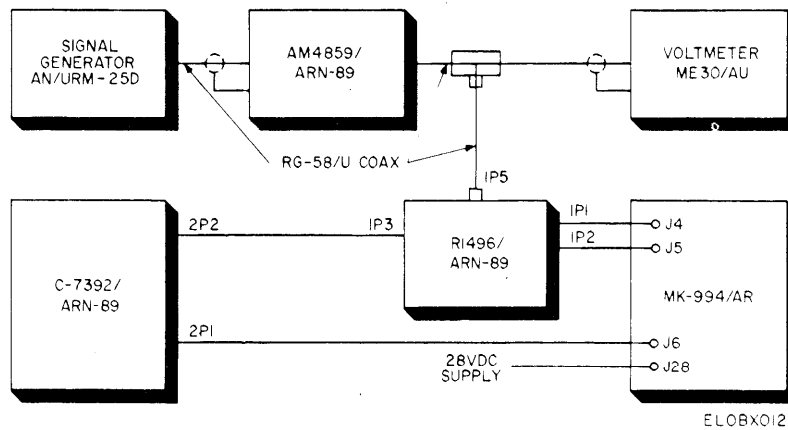
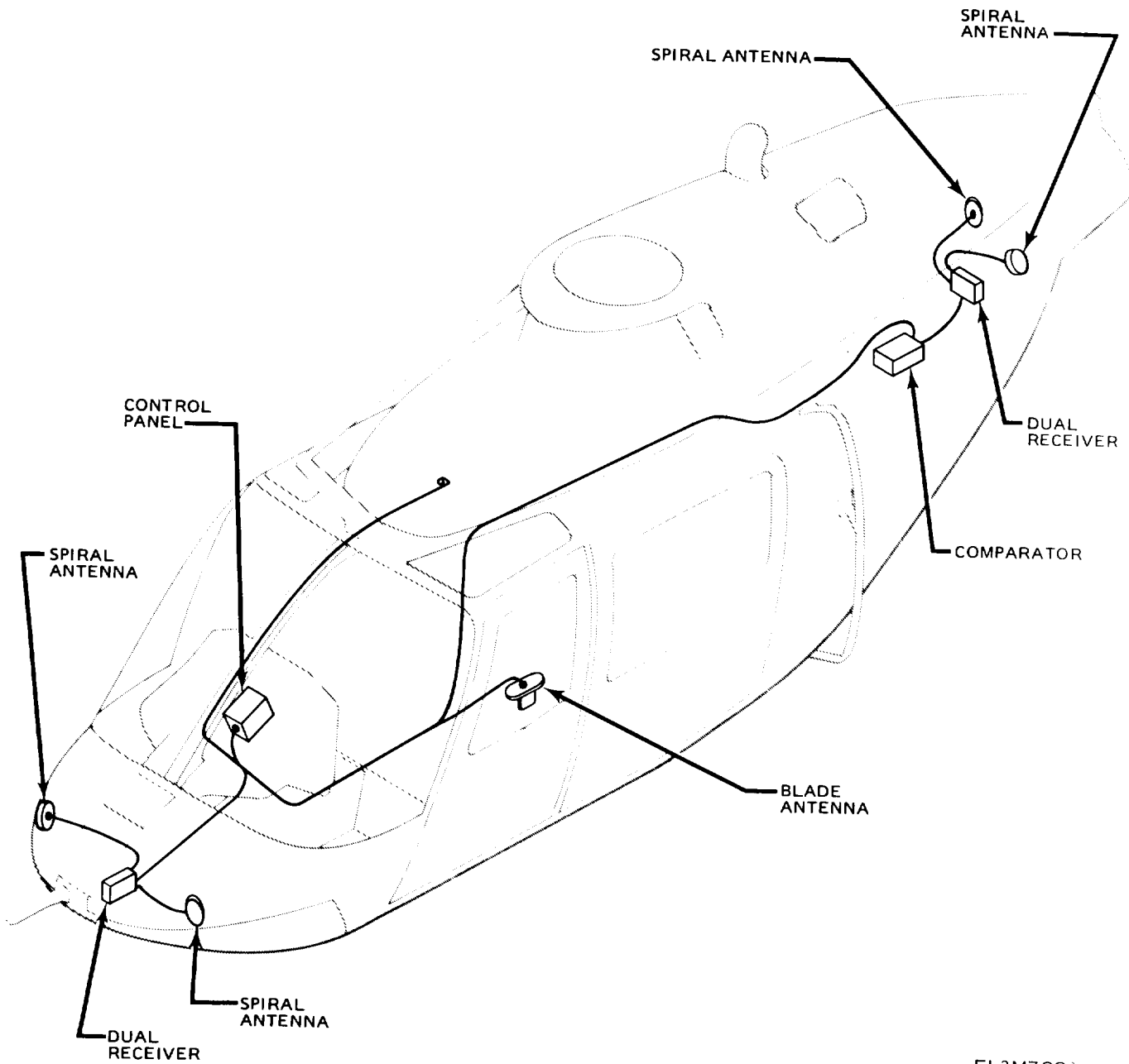

Figure 3-17. Impedance-matching network test setup.





EL2MZ002

Figure 3-18. Radar warning configuration.

## CHAPTER 4

### DIRECT SUPPORT TESTING PROCEDURES

#### Section I. INTRODUCTION

##### 4-1. General

a. These testing procedures are prepared for use by maintenance shops and supporting service organizations responsible for performing direct support maintenance on avionics electronic equipment to determine the acceptability of repaired equipment. These procedures set forth specific requirements that a repaired electronic equipment must meet before it is returned to the using organization.

b. When general support maintenance teams operating within a depot (or operating under depot supervision) have performed minor repairs on an equipment which is to be returned to the user instead of to Army supply stocks, deviations from the testing procedures may occur if:

- (1) The deviation does not result in a lower performance standard.
- (2) The specific deviations are approved by

the quality assurance officer of the applicable depot.

c. The performance standards listed in the tests assume that all pertinent modification work orders have been performed. Check the current issue of DA Pam 310-7 to find the latest listing of modification work orders of the equipment under test. Tests required for the equipment included in this publication are a part of the appropriate manuals referenced in appendix A.

##### 4-2. Test Equipment

A multimeter TS-352B/U is required to perform the testing procedures in this chapter. This item is authorized under TA 11-17, Direct Support Maintenance Shops (Electronics), and TA 11-100, Allowances of Electronic Command Expendable Supplies for Direct Support Maintenance Shops, Continental United States.

#### Section II. TESTING

##### 4-3. Impedance-Matching Network

Verify that resistance between impedance-matching network pin 28 and all pins from 29 through 44 is 150 ohms when the network is removed from the helicopter.

##### 4-4. VHF/FM Antenna

a. Disconnect one of the two antenna connectors on tail assembly.

b. Check for an infinite resistance by placing one lead of Multimeter TS-352B/U on the connector pin and the other lead to the connector shield.

c. Check for an infinite resistance by placing one lead of the multimeter on the connector shield and the other lead to a bare metal surface on the airframe.

d. Repeat a, b, and c above for the other antenna connectors.

##### 4-5. No. 2 Fm Antenna

a. Disconnect coaxial cable connector from No. 2 fm antenna.

b. Check for an infinite resistance by placing one lead of Multimeter TS-352B/U on the antenna connector pin and the other lead to the connector shield.

c. Check for an infinite resistance by placing one lead of the multimeter on the connector shield

and the other lead to a bare metal surface on the airframe.

##### 4-6. Capacitor Board

Verify that capacitors are properly connected (fig. 3-13). With Multimeter TS-352B/U, check capacitors for capacitive-kick (low resistance increasing to high resistance), using highest resistance range on multimeter. Final resistance shall be 2200 ohms.

##### 4-7. Static Inverter

a. Testing of the static inverter requires the following test equipment:

<i>None</i>	<i>Description</i>
Voltmeter	0-20 volts dc
Ammeter	0-10 amperes dc
Voltmeter	0-150 volts ac
Frequency meter	400 ±20 Hz
Load bank	(See Note)
Circuit breaker	5.0 amperes
Circuit breaker	1.0 ampere
Oscilloscope	.....
Power Source	28 v dc, 10 amperes-, adjustable 22 to 28 vdc

#### NOTE

Load bank capable of supplying 65, 150, 250 and 300 VA loads may be locally fabricated in accordance with figure 4-1.

b. Connect the inverter, load bank and instrumentation in accordance with the test setup shown in figure 4-2. The LOAD switch shall be in DISCONNECT, and the LOAD SELECT switch shall be in 65 VA position.

c. Close the 5 and 1 ampere circuit breakers. Adjust dc power supply for 28  $\pm 0.5$  volts. Check that output voltage and frequency are 113.5  $\pm$  8.5v ac and 400  $\pm 2.0$  Hz, respectively, and that the wave form is sinusoidal.

d. Place LOAD switch to CONNECT. Check that input current is 3.7  $\pm 0.3$  amperes for the 206-075-3644 Inverter or 5.2  $\pm 0.3$  amperes for the 206-075-364-5 Inverter. Also check that output voltage and frequency are 113.5  $\pm 6v$  ac and 400  $\pm 20$  Hz, respectively, and that the wave form remains sinusoidal.

e. Press SHORT CIRCUIT switch and hold for approximately 1 minute. During this time check to see that the output voltage is reduced and that the input current is less than 1.0 ampere.

f. After releasing the SHORT CIRCUIT switch, check to see that normal inverter operation is restored.

g. Adjust the input voltage to 22  $\pm 0.5$  volts. Check to see that the input current does not exceed 6.0 amperes for the 206-075-364-3 Inverter or 7.0 amperes for the 206-075-364-5 Inverter. Also check to see that the voltage and frequency are 113.5  $\pm 8.5v$  ac and 400 120 Hz, respectively, and that the wave form remains sinusoidal.

**4-8. Testing Procedures, IFF System-AN/APX-72**

a. *Purpose of External Test Equipment for IFF Set.* The AN/APM-123(V)1 transponder test set (fig. 4-3) provides a coded radiofrequency (rf) interrogation signal to check the transponder set receiver and decoder and, in addition, check the transponder set transmitter and coder by evaluating the coded rf replies. The test set can be directly coupled to the transponder antenna system using Antenna Test Hood MX-4396/APM-123(V)1 in conjunction with the 55db attenuator. (fig. 4-5)

**CAUTION**

Failure to use the 55-db attenuator will seriously damage the AN/A PM-123(V)1 transponder test set.

b. *Preliminary Test Setup.*

(1) Visually inspect the iff set installation for defects or damage.

(2) Install antenna test hood MS-4396/APM-123(V)1 over AT-884( )/APX antenna.

(3) After the couple to the antenna is made, connect the AN/APM-123(V)1 to either a 28vdc

or 115vac power source.

(4) Connect external power 27vdc to external power receptacle of helicopter.

(5) Close appropriate circuit breakers: energize the AN/APX-72 by setting MASTER switch to STBY and the AN/APM-123(V)1 by setting the 28v DC-OFF-115V AC switch to the selected power. Allow approximately 10 minutes for the equipment to warm up.

c. *Testing—Mode 1 Checks.*

(1) Set the controls on the AN/APM-123(V)1 as follows:

FUNCTION Switch	SYSTEM
MODE	1
CODE Dials	0000
SIDE LOBE SUPPRESSION	OFF

(2) Set the controls on the Control, Transponder C-6280A(P)/APX as follows:

MASTER switch	STBY (for 3 minutes) then NORM
INDENT switch	OUT
M-1 switch	ON
M-2, M-3/A and M-C switches	OUT
MODE 1 code dials	00
MODE 2 code dials (on transponder)	0000
MODE 3 code dials	0000
MODE 4 ON-OUT switch	OUT
AUDIO-OUT-LIGHT switch	OUT
CODE selector (Mode 4)	ZERO

(3) Press the PUSH TO TEST switch on the AN/APM-123(V)1 test set. The ACCEPT light shall illuminate.

(4) Change CODE dials on both AN/APM-123(V)1 and C-6280A(P)/APX to 73.

(5) Press the PUSH TO TEST switch on the AN/APM-123(V)1. The ACCEPT light shall illuminate.

d. *Testing—Modes 2 and 3/A Checks.* Repeat c (1) through (5) above for modes 2 and 3/A using 0000 and 7777 codes for each mode. Mode 2 codes are selected on the code dials on the RT unit.

e. *RAD TEST Mode Checks.* With AN/APM-123(V)1 MODE switch set to TEST and the CODE dials set to 0000, set the C-6280A(P)/APX M-3A code dials to 0000.

(1) Push the AN/APM-123(V)1 PRESS TO TEST switch while holding the RAD TEST-MON switch to RAD TEST. ACCEPT light shall illuminate.

(2) Repeat e for code 7777.

f. *Mode C Checks.* Mode C checks not applicable unless AAU-21A Altimeter-Encoder is installed.

(1) Place the C-6280 A(P)/APX M-C switch to ON and the other mode switches to OUT.

(2) Place the AN/APM-123(V)1 MODE

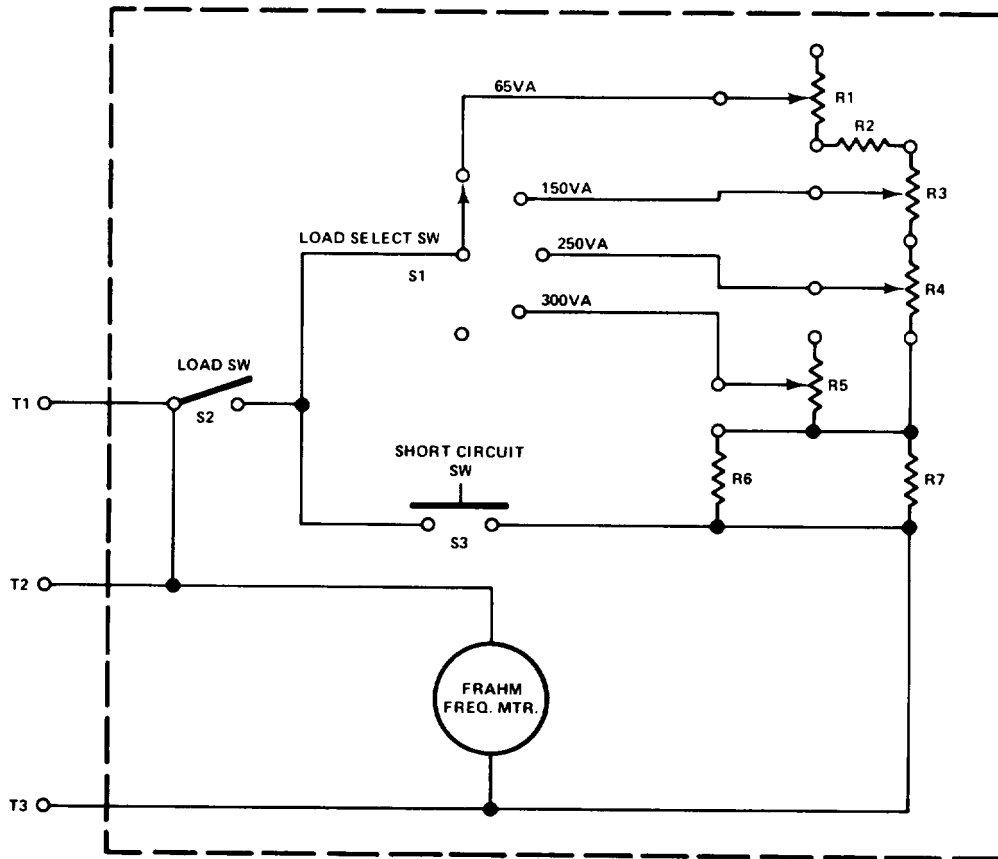

- R1 = 75Ω, 50 WATT
- R2 = 75Ω, 25 WATT
- R3 = 50Ω, 75 WATT
- R4 = 25Ω, 100 WATT
- R5 = 15Ω, 75 WATT
- R6 & R7 = 75Ω, 175 WATT

- S1-1 POLE-5 POSITION ROTARY SWITCH
- S2 = SPST
- S3 = SPST MOMENTARY ON

- T1 - 115V AC INVR HI
- T2 = INSTRUMENTS
- T3 = GROUND

ELOBX027

Figure 4-1. Load bank schematic diagram.

switch to C.

(3) Set 29.92 inches of Hg. in the barometric pressure (in Hg) window on the front of AAU-21A Altimeter-Encoder by turning the barometric zero setting knob.

(4) Observe the altimeter-encoder pointer indication and set the corresponding reply code into the AN/APM-123(V)I as shown in the following chart:

Altimeter Encoder,  
AA U-21/A Pointer  
Indication (feet)

- 200
- 100
- 000
- 100
- 200
- 300
- 400
- 500

Reply code to be set  
into  
ANI/PM-133(v)

- 0640
- 0660
- 0620
- 0630
- 0610
- 0210
- 0230
- 0220

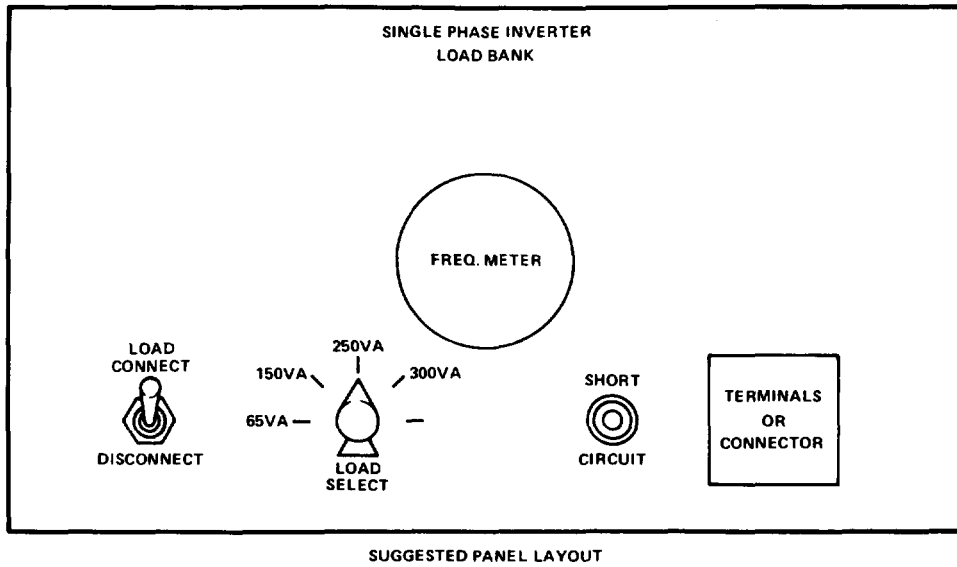

LOAD BANK ADJUSTMENT PROCEDURE  
(INVERTER NOT CONNECTED)

- (1) ATTACH WHEATSTONE BRIDGE TO TERMINALS T1 & T3.
- (2) PLACE LOAD SWITCH TO CONNECT.
- (3) PLACE LOAD SELECT SWITCH TO 300 VA. ADJUST R5 FOR A READING OF  $44 \pm 0.5$  OHMS.
- (4) PLACE LOAD SELECT SWITCH TO 250VA. ADJUST R4 FOR A READING OF  $53 \pm 0.5$  OHMS.
- (5) PLACE LOAD SELECT SWITCH TO 150VA. ADJUST R3 FOR A READING OF  $88.1 \pm$  OHMS.
- (6) PLACE LOAD SELECT SWITCH TO 65VA. ADJUST R1 FOR A READING OF  $203.5 \pm 20$  OHMS.

ELOBX127

Figure 4-2. Load bank panel layout.

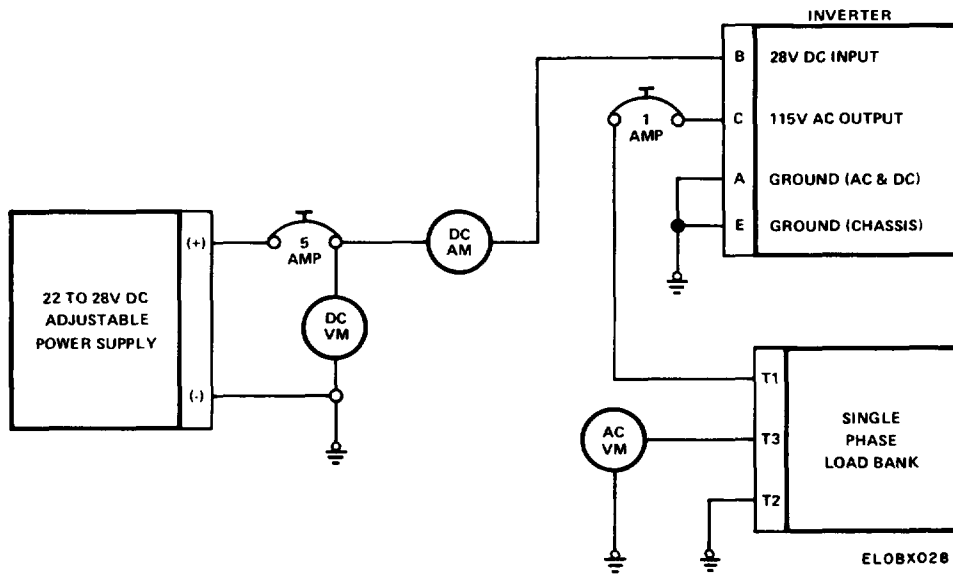

Figure 4-3. Inverter test setup.

Altimeter-Encoder,  
AAU-21/A Pointer  
Indication (feet)

600  
700  
800  
900

Reply code to be set  
into  
AN/APM-123(V) 1

0260  
0240  
0340  
0360

(5) If the pointer indication is 100 feet, then the proper code for the test should be 0630.

NOTE

If the indicated altitude is between two of those listed in (4) above, use the nearest altitude and corresponding code.

Because the altimeter-encoder tolerance is plus or minus 40 feet, it may be necessary to use other altitude and corresponding code.

(6) Depress the AN/APM-123(V)1 PRESS TO TEST switch. The ACCEPT light should illuminate.

g. Emergency Checks.

NOTE

Confine the EMERGENCY position and codes 7600 or 7700 in either modes 2 or 3/A to closed loop testing. Code 7600

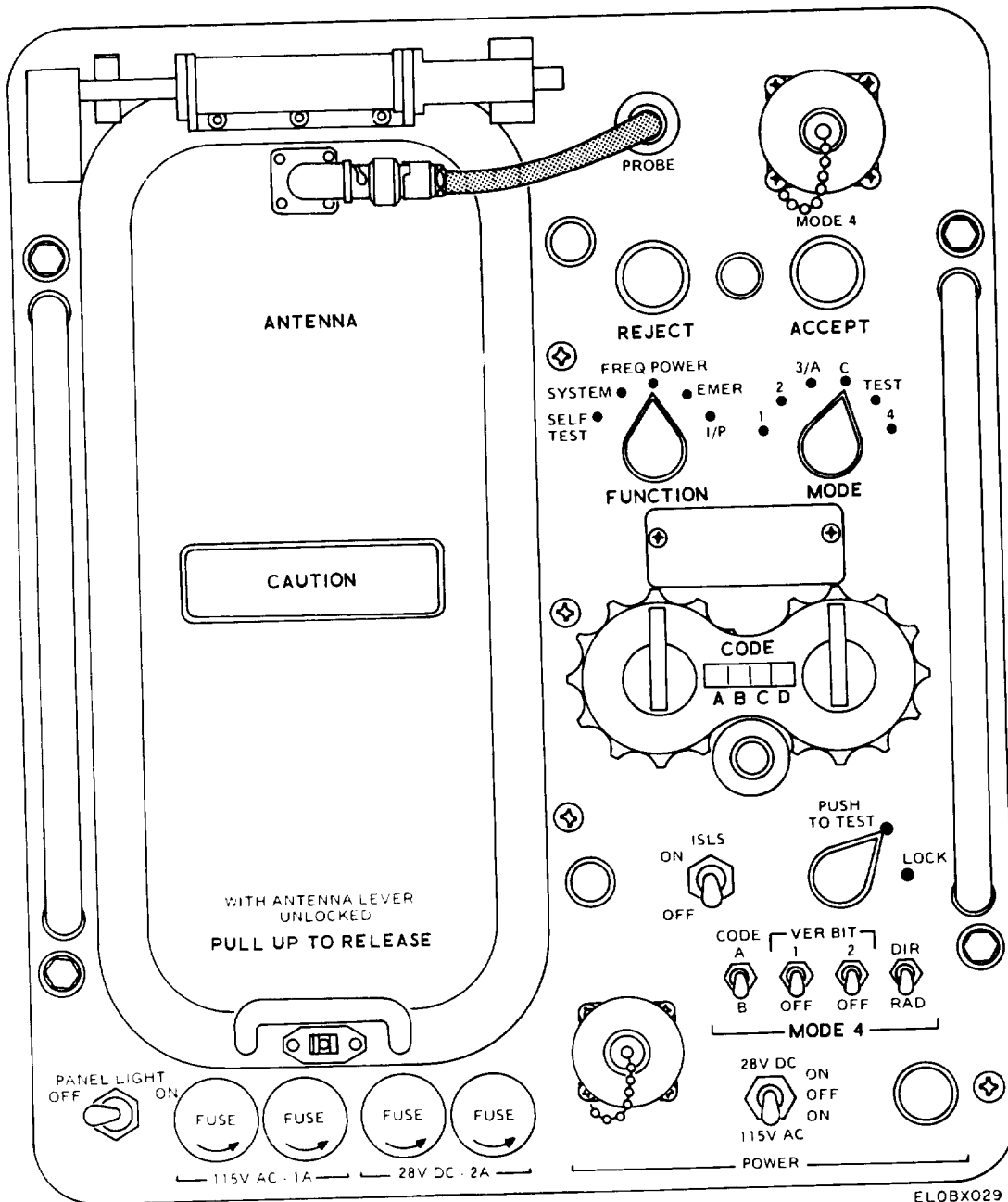

Figure 4-4. Transponder test set AN/APM-123(V) 1

signifies a communications failure and code 7700 signifies an aircraft in distress. On the transponder set control, the two code selector MODE 1 wheels correspond to codes A and B on the test set and the four code selector wheels for modes 2 and 3/A correspond to codes A, B, C and D on the test set.

(1) Set the controls on the C-6280A(P)/APX as follows:

M-1, M-2, M-3	Optional
MODE 1 code dials	00
MODE 2 code dials (on transponder)	0000
MODE 3A code dials	Optional
MASTER switch	EMER

(2) On the AN/APM-123(V)1, set the FUNCTION switch to EMER and press the PUSH TO TEST switch. The ACCEPT light shall illuminate with the AN/APM-123(V)1 MODE switch in position 1 and 2 when the AN/APM-123(V)1 CODE dials match those of the C-6280A(P)/APX.

(3) Repeat (1) above with the AN/APM-

123(V)1 MODE switch set to 3/A and the CODE dials set to 7700. The ACCEPT light shall illuminate regardless of the setting of the C-6280A(P)/APX CODE dials.

*h. Ident Checks.*

(1) Set the controls on the C-6280A(P)/APX as follows:

M-1, M-2, and M-3/A	ON
MODE 1 code dials	00
MODE 2 code (on transponder)	0000
MODE 3/A code dials	0000
MASTER switch	NORM

(2) Set the controls on the AN/APM-123(V)1 as follows:

FUNCTION switch	I/P
MODE switch	I
PUSH TO TEST switch	LOCK
CODE dials	0000

(3) On the C-6280A(P)/APX, momentarily set the INDENT-OUT-MIC switch to IDENT. The ACCEPT light shall illuminate for a period of 15 to 30 seconds.

(4) Repeat (3) above for AN/APM-123(V)1 MODE switch settings of 2 and 3/A.

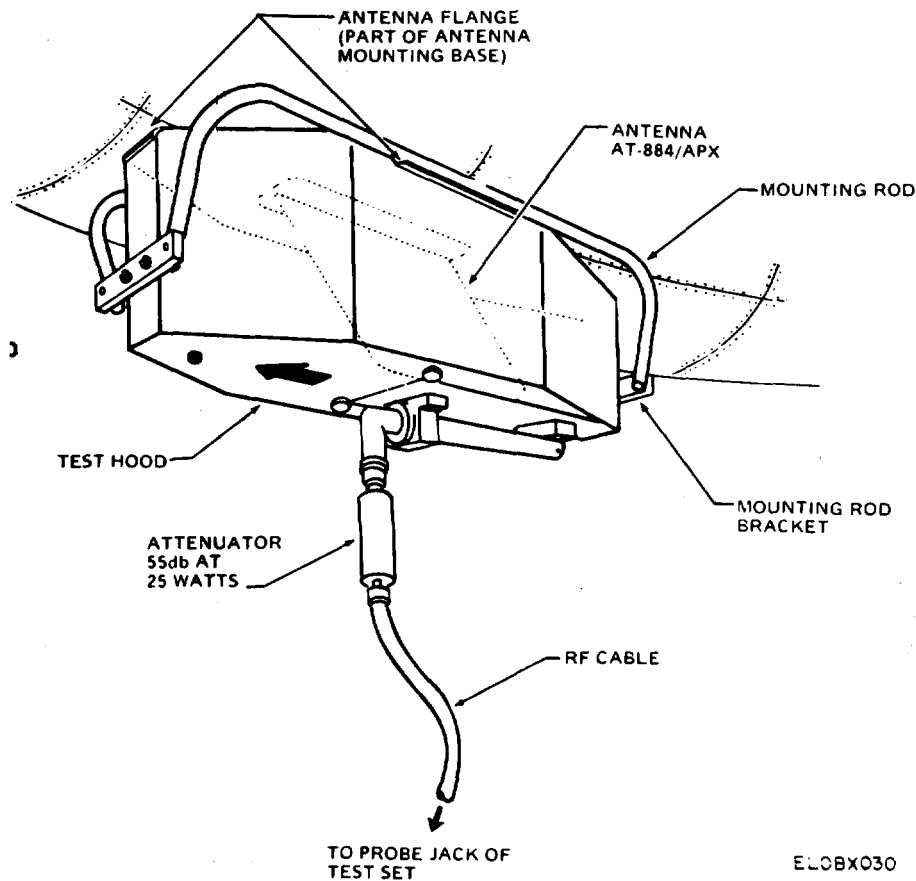

Figure 4-5. Antenna test hood installation MX-4396/APM-123(V) 1

(5) Release PUSH TO TEST switch on AN/APM-123(V)1.

**NOTE**

The MIC position of the IDENT switch is disabled; therefore, no checks are required in the MIC position of the IDENT switch.

*i. Mode 4 Checks.*

(1) Connect Interrogator Computer KIR-1A/TSEC to test set MODE 4 connector using cable CX-12216/APM-123(V). ZEROIZE light on the test set should light.

(2) Using Code Changer Key KIK-18/TSEC, key the KIR-1A and close the access door. ZEROIZE light on the test set should go out.

(3) Install Computer KIT-1A/TSEC in the aircraft.

(4) Connect headset to aircraft intercom system.

(5) Set the controls on the C-6280A(P)/APX as follows:

Control	Position
MASTER	NORM
TEST M-1/OUT	OUT
TEST M-2/OUT	OUT
TEST M-3/OUT	OUT
TEST MC/OUT	OUT
AUDIO/OUT/LIGHT	AUDIO
CODE	A
MODE 4 ON/OUT	OUT

(6) On the test set, place the FUNCTION switch to SYSTEM, the MODE 4 DIR/RAD switch to DIR, the MODE switch to 4, the MODE 4 code A/B switch to A and the PUSH TO TEST switch to the lock position, and when operating test set observe the following:

(a) On the test set, the REJECT light should light.

(b) Audio tone should be heard in headset.

(c) IFF CAUTION light should light.

(7) Using KIK-18/TSEC, key the KIT-1A/TSEC and close access door. Observe same indications listed in (6) above. Release PUSH to TEST switch.

(8) On C-6280A(P)/APX, place the MODE 4 switch to ON.

(9) On the test set, briefly depress the PUSH to TEST switch and observe the following:

(a) On the test set, the ACCEPT light should light.

(b) On the C-6280A(P)/APX, the REPLY light should light.

(c) Audio tone should be heard in headset.

(d) Aircraft IFF CAUTION light should be OFF.

(10) On the C-6280A(P)/APX place the AUDIO/LIGHT switch to the LIGHT position, and repeat the above test. Audio tone should not be heard, but REPLY light should light.

(11) On the test set, place the MODE 4 CODE A/B switch to B and briefly depress the PUSH to TEST switch. The REJECT light should light. Return MODE 4 CODE A/B switch to A.

(12) On the test set, place the MODE 4 VER BIT 1 switch to 1 and briefly depress the PUSH to TEST switch. The REJECT light should light. Return MODE 4 VER BIT 1 switch to OFF.

(13) On the test set, place the MODE 4 VER BIT 2 switch to 2 and briefly depress the PUSH to TEST switch. The REJECT light should light. Return MODE 4 VER BIT 2 switch to OFF.

(14) On the test set, place the ISLS switch to ON and briefly depress PUSH to TEST switch. The REJECT light should light. Return ISLS switch to OFF.

(15) Set IFF CODE HOLD switch located on aircraft instrument panel to ON. IFF CODE HOLD light located on aircraft instrument panel should light.

(16) On C-6280A(P)/APX, place CODE switch to HOLD, then return to A.

(17) Wait at least 15 seconds and then on the C-6280A(P)/APX turn MASTER switch to OFF.

(18) Wait at least 15 seconds and then on the C-6280A(P)/APX turn MASTER switch to STBY for a warmup of about 30 seconds; then turn MASTER switch to NORM.

(19) On the test set, briefly depress PUSH to TEST switch. ACCEPT light should light.

(20) On the C-6280A(P)/APX pull out CODE switch and turn to ZERO and place AUDIO/LIGHT switch to AUDIO position.

(21) On the test set, place PUSH to TEST switch to LOCK position, and observe the following:

(a) On the test set the REJECT light should light.

(b) Audio tone shall be heard in headset.

(c) IFF CAUTION light should light.

*j. Test Procedure Using TS-1843/APX.*

(1) Set the controls on the C-6380A(P)/APX as follows:

Control	Position
MASTER switch	NORM
IDENT	OUT
MODES 1, 2, 3/A	ON
M-C	OUT
MODE 1 CODE	Any code
MODE 3/A CODE	Any code
RAD TEST-OUT-MON	OUT

(2) Place M-1 switch on the C-6280A(P)/APX in the TEST position.



(3) The green TEST light on the C-6280A(P)/APX should illuminate, indicating the following conditions exist:

(a) The TS-1843 has initiated an interrogation of power MODE 1 signals.

(b) The RT-859/APX-72 has recognized the interrogation and transmitted reply.

(c) The TS-1843 has evaluated the reply and is satisfied that the frequency (1090 plus or minus 3.0 MHz) the power (20 to 28 dbw), the bracket pulse spacing (20.3 plus or minus 0.15 usec.) and the antenna vswr (8 plus or minus 2.5 db or less) are within specified limits.

(4) Repeat (2) and (3) above for MODES 2, 3/A and C.

(5) Place FUNCTION selector in SYSTEM position.

(6) Place RAD TEST-OUT-MON switch in MON position, repeat MODE 1 Checks, and observe that the test light glows whenever the ACCEPT indicator remains illuminated on the

AN/AMP-123-V. Place the RAD TEST-OUT-MON switch in RAD TEST position and note that the TEST light does not illuminate. This demonstrates that the TEST light on the C-6280A(P)/APX will not illuminate when being interrogated in the TEST mode if the RAD TEST-OUT-MON switch is in RAD TEST position.

**NOTE**

The TEST light may blink out momentarily at a slow steady rate while in MON. This is normal and does not indicate a failure. No light or a random flickering light shall indicate. When not conducting a MON check for an extended period of time return RAD TEST-OUT-MON switch to OUT Position.

(7) Remove electrical power from the IFF set.

## CHAPTER 5

### GENERAL SUPPORT MAINTENANCE

#### 5-1. General Instructions

The general support maintenance procedures in this chapter would supplement the direct support maintenance procedures in chapter 3 to provide complete instructions for maintaining the electronic equipment configuration and individual electronic equipments that are part of the electronic equipment configuration. However, the No. 2 fm antenna, VHF/FM, and uhf antennas cannot be repaired; refer instead to TM 11-1520-228-20 for replacement instructions.

#### 5-2. Audio Threshold System

a. The following information is required for maintenance of the Audio Threshold System (ATS) and includes appropriate bench testing instructions and troubleshooting procedures.

**NOTE**

Because of the time element involved and different test setups required, the following bench test procedures are presented in two separate phases—the audio section and the control section.

b. The ATS contains special transformer coupling networks and a relay network. The transformer coupling networks couple radio transmit audio signals to the appropriate radio facilities and block low amplitude audio signals which generally occur from cross-talk. During voice security operation, the relay circuits insure adequate cross-talk isolation by muting secures-voice audio sidetone from the ICS station keying a nonsecure radio facility.

#### 5-3. Test Equipment, ATS

The following listed test equipment is required to perform the testing procedures presented in this section:

<i>Equivalent Army test equipment</i>	<i>Common name</i>
Multimeter AN/USM-223	Multimeter
Oscilloscope AN/USM-120	Oscilloscope
Voltmeter, Electronic ME-30E/U	Electronic voltmeter
Oscillator, Audio Frequency AN/URM-127(NSN 6625-00-678-5616)	Audio frequency oscillator
Power supply, 27.5 ±0.5 vdc	Power supply

#### 5-4. Test Procedures, ATS Audio Section

Set up the audio section test equipment as shown in figure 5-1.

a. The following input and output terminals must be utilized for the audio section tests:

<i>Channel No.</i>	<i>Pin No.</i>	<i>Input terminal (J1) function</i>	<i>Pin No.</i>	<i>Output terminal (J2) function</i>
1	C4	Input high	C5	Output high
	A2	Input low	D4	output low
2	A3	Input high	D5	Output high
	B4	Input low	C6	output low
3	A4	Input high	D6	Output high
	B3	Input low	B6	output low

b. Connect a 150-ohm resistor across the audio frequency oscillator output terminals. Connect the electronic voltmeter across the audio frequency oscillator, 150-ohm resistor and electronic voltmeter combination across the input high and low terminals of channel 1 of the ATS.

c. Connect a 150-ohm resistor and the oscilloscope across the output high and low terminals of channel 1 of the ATS.

d. Adjust the audio frequency oscillator to produce a 1000-hertz, 300-millivolt reading on the electronic voltmeter.

e. Observe the oscilloscope presentation. The signal should appear approximately as shown in figure 5-2 and should be between 120 and 160 millivolts rms or 320 and 450 millivolts peak to peak. The electronic voltmeter leads may be changed to the output terminals temporarily to check the rms reading if the oscilloscope peak-to-peak reading is marginal.

**NOTE**

Do not move the 150-ohm resistors on the input and output terminals until the conclusion of the tests on the channel under test.

f. Return the electronic voltmeter leads to the input terminals if they were moved in e above.

g. Set the level on the audio frequency oscillator to produce a voltmeter reading of 10 millivolts. The reading on the oscilloscope should be less than 5 millivolts peak-to-peak.

h. Set the audio frequency oscillator to produce again a reading of 300 millivolts on the electronic voltmeter. Move the oscilloscope connections to the other two channel output terminals sequentially. The oscilloscope presentation, when the terminals are connected to each set of output terminals of the other two channels, should be less than 5 millivolts peak-to-peak.

i. Using the multimeter, perform the following measurements:

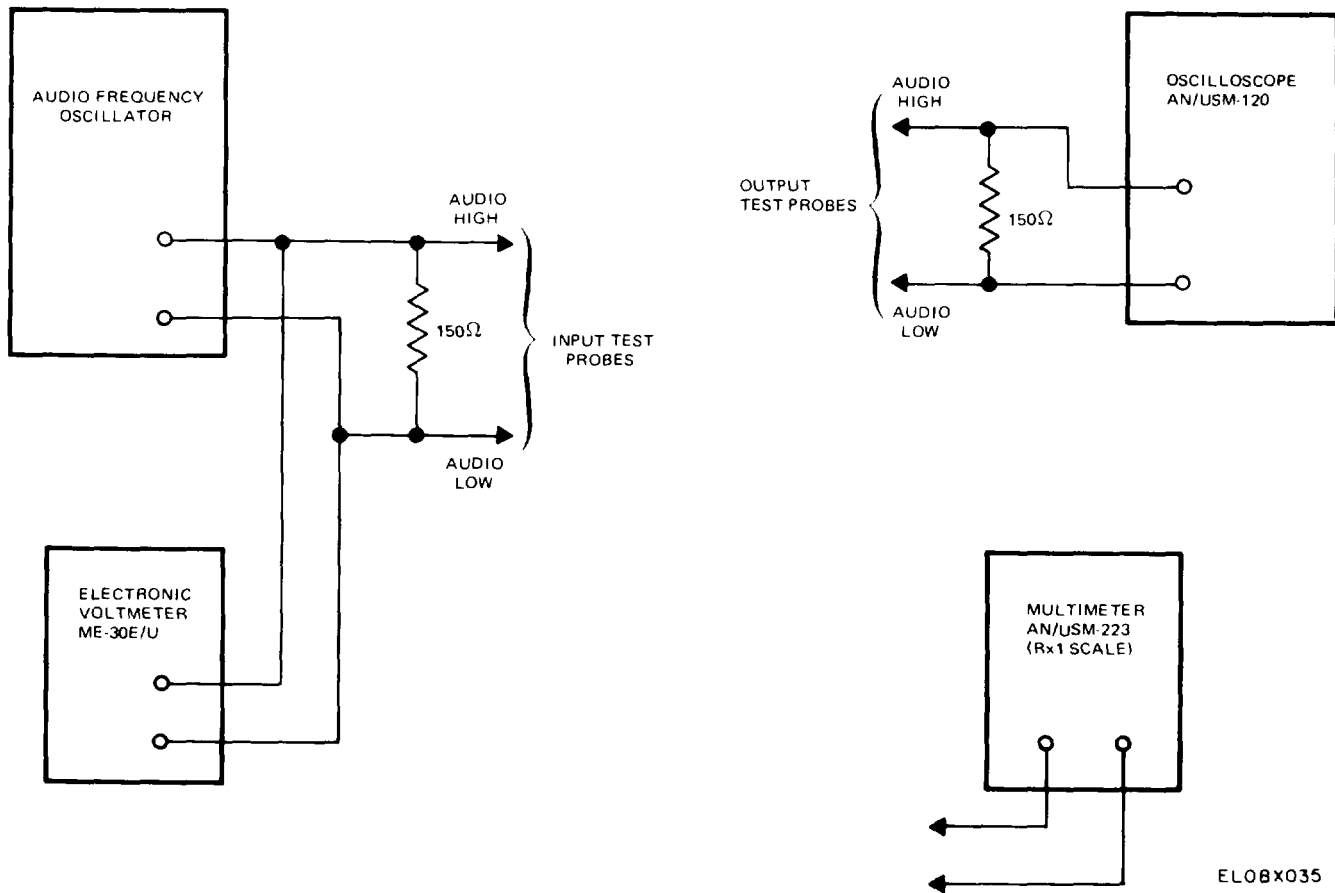

Figure 5-1. ATS test setup-audio section.

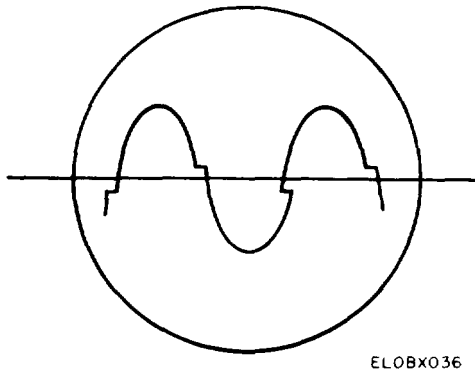

Figure 5-2. ATS audio output waveform.

Terminal	to	Terminal	Indication
J1-C3		J2-B5	Less than 1 ohm
J1-D4		J2-A6	Less than 1 ohm
J1-D3		J2-A5	Less than 1 ohm
J1-C1		J1-B2	50 ±15 ohms
J1-C1		J1-C2	50 ±15 ohms

j. Using applicable channel terminals specified in *a* above, perform *b* through *h* above on channels 2 and 3 of the ATS.

k. If any portion of the above tests fails to meet requirements specified, refer to applicable audio section troubleshooting procedures for corrective action.

**5-5. Test Procedures, ATS Control Section.**

*a. Preliminary Test Setup, Control Section (fig. 5-3).*

(1) Connect ATS terminal J1-C1 to a common ground point such as the low side of the 28 vdc power supply.

(2) Connect ATS terminal J1-B1 through a 1,000-ohm resistor to ground.

(3) Connect the multimeter black lead to ground. The red lead will be designated the meter probe for the following tests.

(4) Connect the low side of the 28 vdc power supply to ground if not already accomplished in (1) above.

(5) Connect a 28-volt lamp on the high side of the 28 vdc power supply and connect a probe to the other side of the 28-volt lamp so that feed-through terminals of the ATS may be probed as

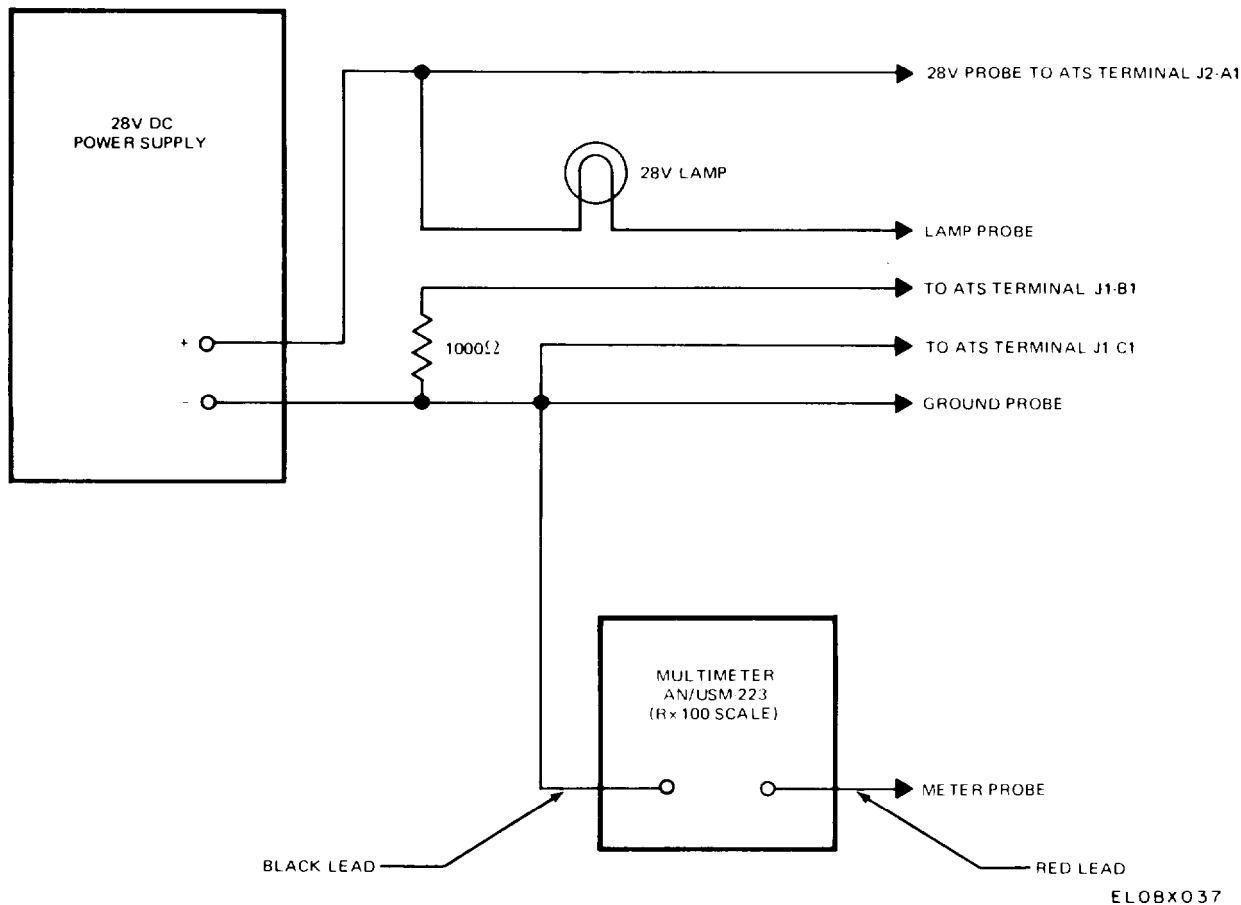

Figure 5-3. ATS test setup-control section.

directed in the subsequent tests. This will be designated the lamp probe.

(6) Connect a probe to the ground point. This will be designated the ground probe.

(7) Connect the 28 vdc power supply high side terminal to ATS terminal J2-A1.

*b. Testing, Control Section.*

(1) Use the chart in (2) below for testing the control section. Sequentially position the test setup ground probe on the terminals indicated by the ground probe column of the test chart. At each step of the tests, position the test setup meter probe on ATS terminals J1-D2, J1-D1 and J1-A1, in order. Also at each step of the tests, position the test setup lamp probe on terminals

J2-A4, J2-A2, and J2-A3, in order. Compare the test results with the performance standards specified in the test chart.

(2) In the following test chart, an X in the meter probe columns indicates a reading of less than 1 ohm on the multimeter while the test setup meter probe is connected to that terminal. The absence of an X in the meter probe columns indicates a reading of 1,000 ±100 ohms while test setup meter probe is connected to that terminal. An X in the lamp must illuminate while connected to that terminal. The absence of an X in the lamp probe columns indicates the test setup lamp must not illuminate while connected to that terminal.

Step	Ground probe to terminal	Meter probe to terminal			Lamp probe to terminal	
		J1-D2	J1-D1	J1-A1	J2-A4	J2-A2 J2-A3
1	(Not applicable)					
2	J2-C4	X			X	
3	J2-D3		X		X	
4	J2-C2			X	X	

Step	Ground probe to terminal	Meter probe to terminal				Lamp probe to terminal
		J1—D2	J1—D1	J1—A1	J2—A4	
5	J2-B2	x				x
6	J2-C1		x			x
7	J2-D1			x		x
8	J2-B1	x				x
9	J2-C3		x			x
10	J2-D2			x		x

(3) If any portion of the above tests fails to meet requirements specified, refer to applicable control section troubleshooting procedures for corrective action.

**NOTE**

The following troubleshooting procedures are presented separately for the audio section and the control section, conforming with bench testing presentation.

**5-6. Troubleshooting ATS Audio Section**

Utilize ATS schematic diagram (fig. 5-4) with the following troubleshooting chart to perform ATS audio section troubleshooting.

**NOTE**

ATS input transformers and capacitors are connected to the input terminals in feedthrough J1. Output transformers and capacitors are connected to output terminals in feedthrough J2.

Fault	Probable cause	Solution
Inadequate input signal.	Shorted input or output capacitor or transformer.	Perform continuity checks and replace defective part.
Inadequate output signal.	a. Shorted input or output capacitor or transformer. b. Open circuit in input or output transformer or signal diode.	a. Perform continuity checks and replace defective part. b. Perform continuity checks and replace defective part.
Excessive output.	Defective transformer.	Perform continuity checks and replace defective part.
Distorted output.	Open signal diode.	Perform resistance measurements and replace defective diode.
No low signal isolation.	Shorted signal diode.	Perform resistance measurements and replace defective diode.
Inadequate isolation between channels.	Defective wiring in circuit and board assembly.	Perform continuity checks and replace or repair defective wiring.

**5-7. Troubleshooting ATS Control Section**

If trouble has been encountered during bench testing of the ATS control section (para 5-5) repeat the tests and observe the pattern of discrepancies. Compare the discrepancies with the failure patterns listed in the following discrepancy chart to isolate the faulty component. The failure patterns contained in the discrepancy chart are consistent with a single component failure. If more than one failure exists, it will be necessary to troubleshoot using the ATS schematic diagram (fig. 5-4) and the multimeter. Open circuit board wiring or poor solder joints can also appear to be a component failure. If replacing the part indicated by the discrepancy chart does not correct the fault, perform continuity checks and replace or repair defective wiring.

Failed step(s) of test chart (para. 5-5)	Failure indication	Defective Component
1	J1-D2 reads low	K1
1	J1-D1 reads low	K2
1	J1-A1 reads low	K3
2 only	J1-D2 reads high	CR7
2 only	J2-A4 does not light	CR24
2,3	J1-A1 reads low	CR22
2,4	J1-D1 reads low	CR23
2,5	J2-A3 lights	CR9
2,5,8	J1-D2 reads high	K1
2,8	J2-A2 lights	CR8
3 only	J1-D1 reads high	CR10
3 only	J2-A4 does not light	CR23
3,4	J1-D2 reads low	CR24
3,6	J2-A3 lights	CR12
3,6,9	J1-D1 reads high	K2
3,9	J2-A2 lights	CR11
4 only	J1-A1 reads high	CR13
4 only	J2-A4 does not light	CR22
4,7	J1-A3 lights	CR15
4,7,10	J1-A1 reads high	K3
4,10	J2-A2 lights	CR14
5 only	J2-A4 does not light	CR8
5 only	J2-A2 does not light	CR21
5,6	J1-A1 reads low	CR19
5,7	J1-D1 reads low	CR20
5,8	J2-A4 lights	CR7
6 only	J1-D1 reads high	CR11
6 only	J2-A2 does not light	CR20
6,7	J1-D2 reads low	CR21
6,9	J2-A4 lights	CR10
7 only	J1-A1 reads high	CR14
7 only	J2-A3 does not light	CR19
7, 10	J2-A4 lights	CR13
8 only	J1-D2 reads high	CR9
8 only	J2-A3 does not light	CR18
8,9	J-A1 reads low	CR16
8,10	J1-D1 reads low	CR17

Failed step(s) of test chart (para. 5-5)	Failure indication	Defective Component
9 only	J1-D1 reads high	CR12
9 only	J2-A3 does not light	CR17
9,10	J1-D2 reads low	CR18
10 only	J1-A1 reads high	CR15
10 only	J2-A3 does not light	CR16

### 5-8. Disassembly, ATS

Disassemble the ATS components in accordance with the following procedures and figures 5-5 and

- NOTES:  
 1. DIODES CR1-CR6 ARE 1N3595, DIODES CR7-CR24 ARE 1N2071.  
 2. ALL CAPACITORS ARE 470PF, 15%.  
 3. R1 IS 150 OHMS, 1/2 W.  
 4. 4,5;6,7 INDICATES RESPECTIVE TERMINALS ARE BUSSED.

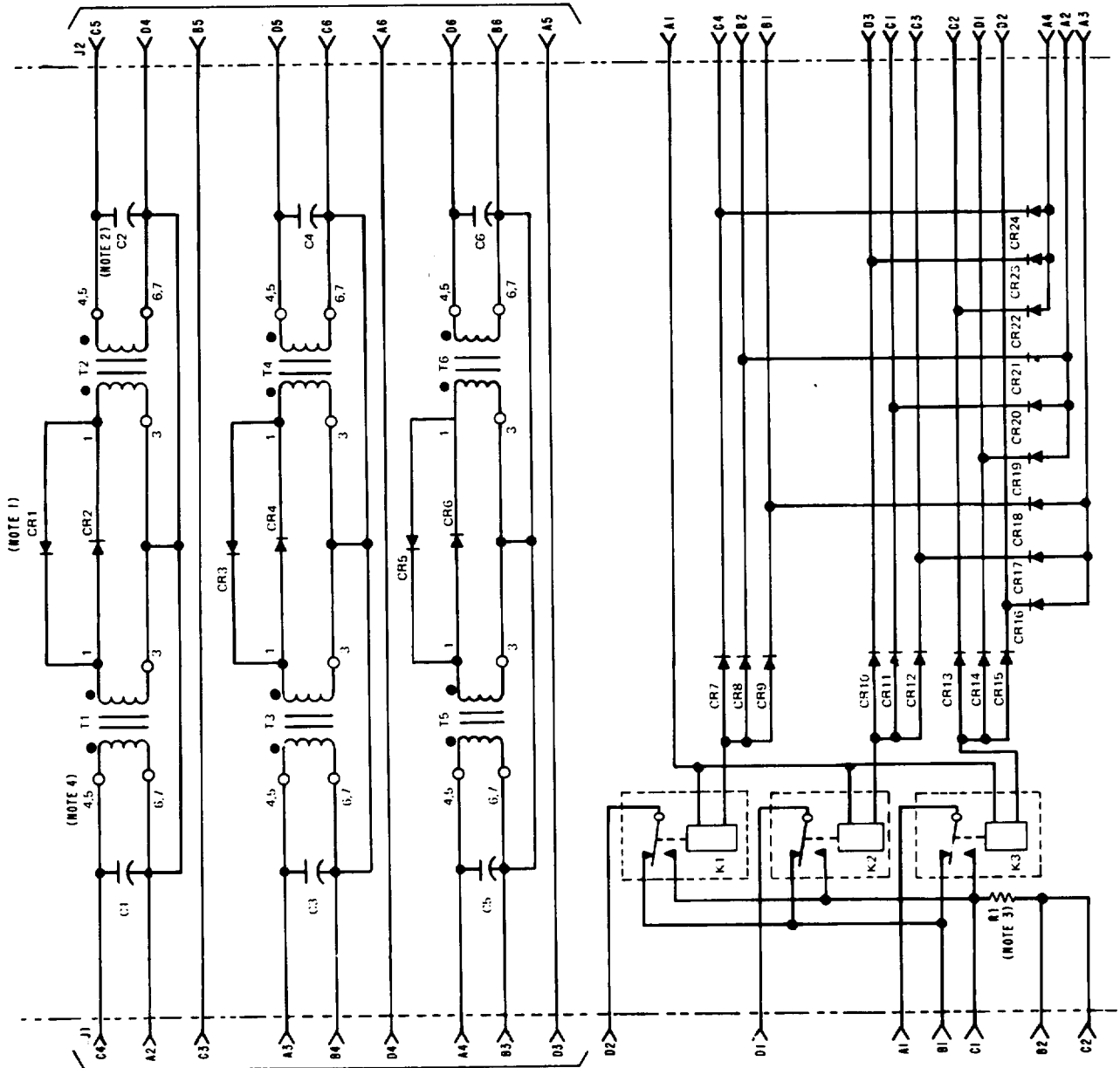

ELOBX038

Figure 5-4. ATS schematic diagram.

5-6.

a. Remove the cover from the chassis by removing the eight screws, eight lockwashers, and eight flat washers. Lift cover from the ATS.

b. Remove the circuit board assembly from the chassis by removing the six screws, six lockwashers, and six flat washers. Lift circuit board assembly from the chassis.

c. Do not remove the nameplate from the cover, except for damage. If required, the nameplate peels off the cover.

d. Further disassembly is accomplished by unsoldering connection of parts mounted to the circuit board assembly (fig. 5-6). Disassembly only to the extent required to replace a faulty part. To remove connectors J1 and J2, mounting hardware must be removed in addition to unsoldering the leads to the circuit board assembly.

(1) To remove connector J1, remove four

screws, four lockwashers, six flat washers and two spacers. Unsolder the connection to the circuit board assembly.

(2) To remove connector J2, remove the four screws, four lockwashers, six flat washers, and two spacers. Unsolder connections to circuit board assembly.

e. Refer to figure 5-6 to locate parts when replacement of a faulty part is found to be necessary. Parts are coated with Polyurethane, MIL-I-46058, Type PUR. It will be necessary to remove the coating when replacing a part.

**5-9. Cleaning, ATS**

a. Remove moisture, dust and loose dirt with a clean, soft cloth.

**WARNING**

The fumes of trichloroethane are toxic. Provide thorough ventilation when

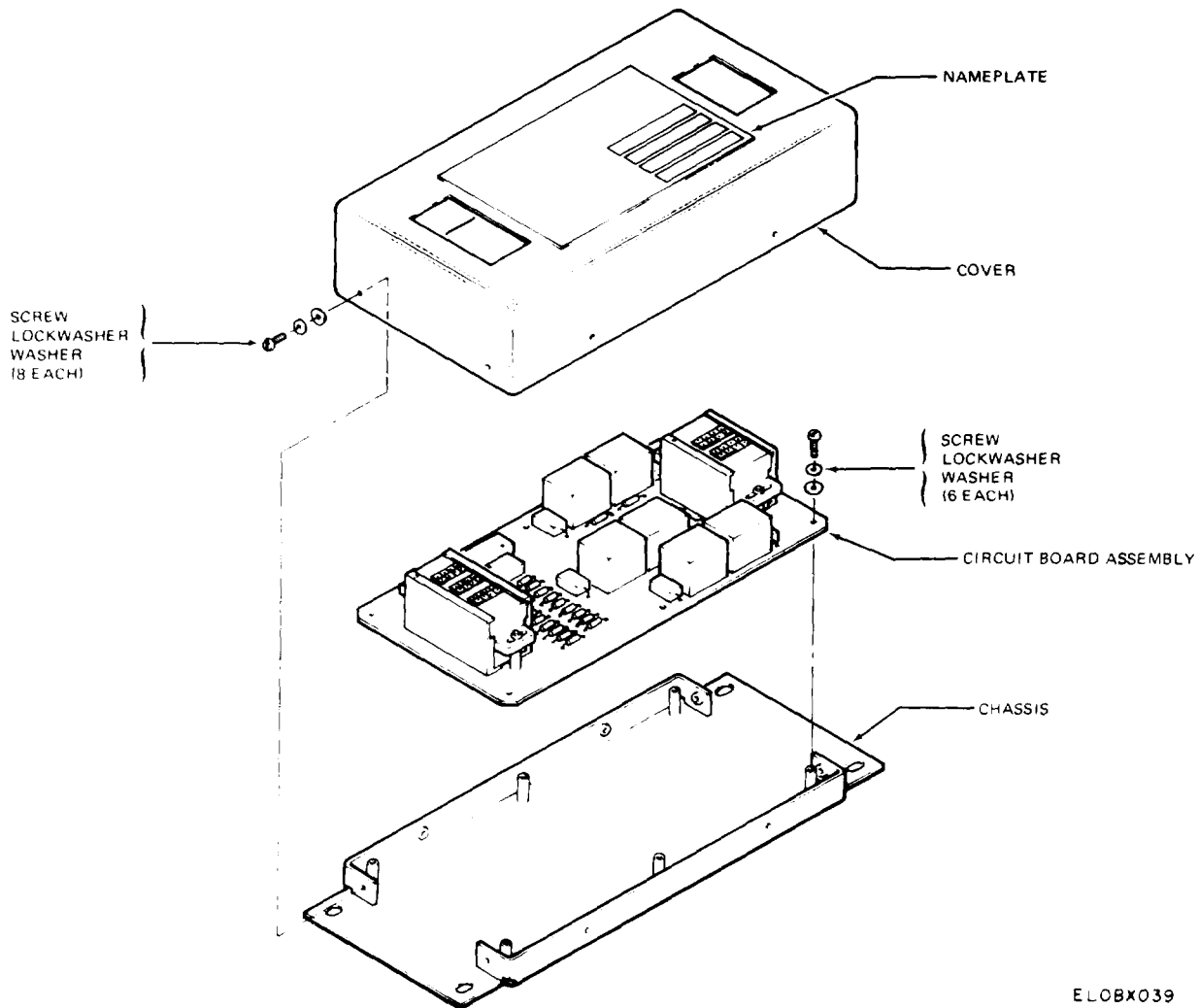

ELOBX039

Figure 5-5. ATS-exploded view.

used. DO NOT use near open flames. Trichloroethane is not flammable, but exposure of fumes to open flame converts the fumes to highly toxic, dangerous gases.

b. Remove grease, fungus, and ground-in dirt from the ATS unit and mountings; use a cloth dampened (not wet) with trichloroethane, technical: liquid form, per Federal Specification

O-T-620, Type I.

c. Remove dust from all exposed connectors with a brush; remove moisture with a dry cloth.

**5-10. Inspection, ATS**

The following chart specifies inspection and repair requirements of disassembled parts. Inspect parts for damage, wear or deterioration and repair or replace parts that fail to meet inspection requirements.

Item	Inspect for	Repair
Cover	Punctures, deep dents, and damage to finish requiring touchup.	Touchup or replace.
Chassis	Punctures, deep dents, damaged fasteners and damage to finish requiring touchup.	Touchup or replace.
Circuit board assembly:		
Printed circuit board	Cracked board or damaged surface coating.	Replace or recoat.
Solder joints	Loose or cold solder joints.	Resolder.
Connectors	Insert damage.	Replace connector.
Parts on circuit board assembly	Physical damage.	Replace part.

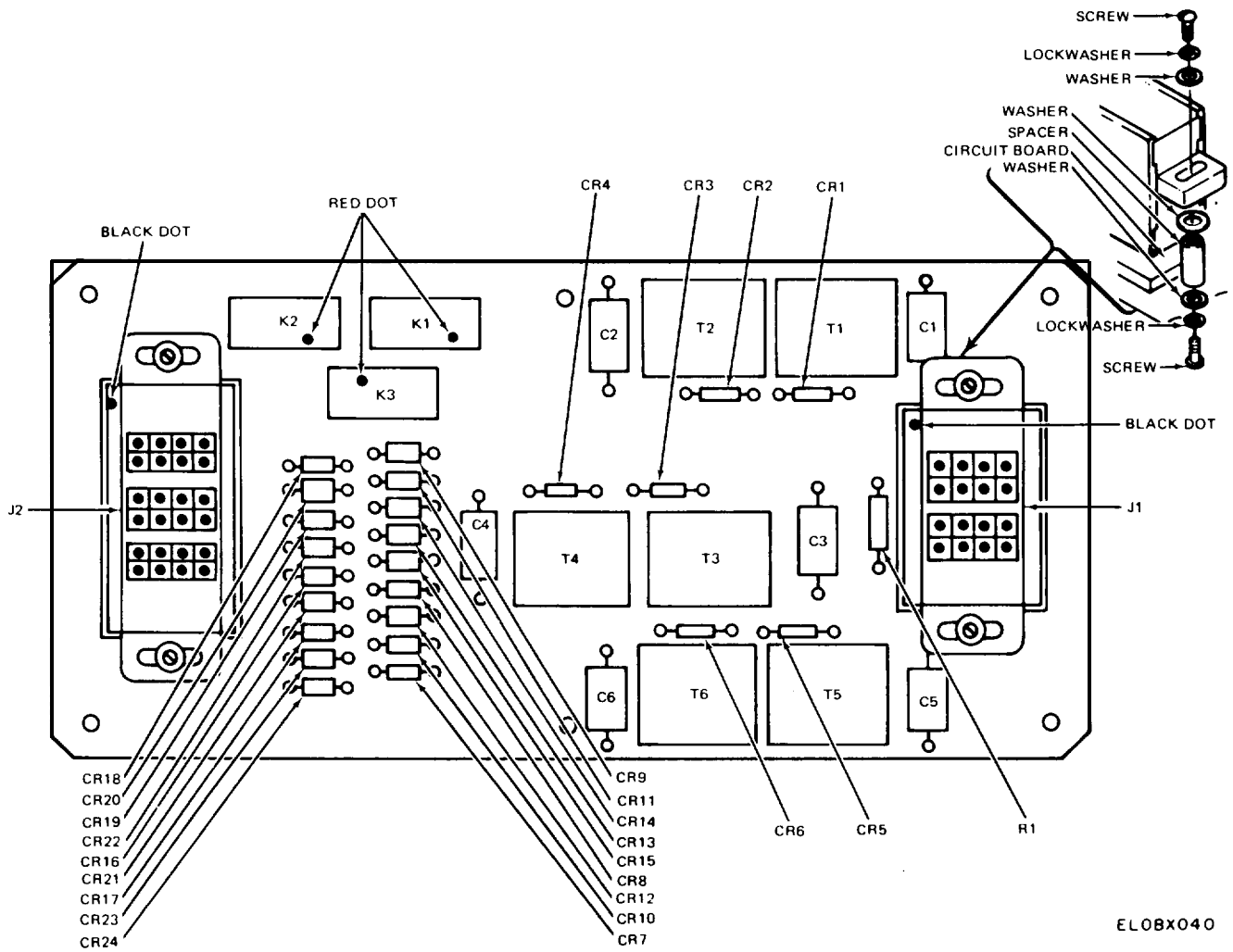

Figure 5-6. ATS circuit board assembly.



**5-11. Assembly, ATS**

Reassemble the ATS components in accordance with the following procedures and figures 5-5 and 5-6.

*a.* Remount removed or replaced components on the circuit board assembly in the same location and orientation from which they were removed (fig. 5-6). During reassembly, use the same mounting hardware removed during disassembly (para 5-8).

*b.* Mount the circuit board assembly on the chassis so that the circuit board assembly mounting holes and the chassis mounting nuts align. Secure the circuit board assembly to the chassis using the six screws, six lockwashers, and six flat washers removed during disassembly.

*c.* Place the cover on the chassis. Secure the cover to the chassis using the eight screws, eight lockwashers, and eight flat washers removed during disassembly.

## APPENDIX REFERENCES

---

**A-1.**

The complete technical manual for Army Model Helicopter, Observation, OH-58A includes the following publications:

TM 11-1520-228-20	organizational Maintenance Manual: Electronic Equipment Configuration Army Model OH-58A Helicopter. (NSN 1520-00-169-7137)
TM 11-1520-228-24P	Organizational, Direct Support, and General Support Maintenance Manual Repair Parts and Special Tools Lists Electronic Equipment Configuration Army Model OH-58A Helicopter. (NSN 1520-00-169-7137)
TM 55-1520-228-20	Organizational Maintenance Manual: Army Model OH-58A Helicopter.
TM 55-1520-228-34	Direct Support and General Support Maintenance Manual, Army Model OH-58A Helicopter.

**A-2.**

The following publications cover practices and regulations directly related to this manual.

DA Pam 310-4	Index of Technical Manuals, Technical Bulletins, Supply Manuals (types 7, 8, and 9), Supply Bulletins, and Lubrication Orders.
DA Pam 310-7	US Army Equipment Index of Modification Work Orders.
SB 11-573	Painting and Preservation Supplies Available for Field Use for Electronics Command Equipment.
TB SIG 222	Solder and Soldering.
TB SIG 355-1	Depot Inspection Standard for Repaired Signal Equipment.
TB SIG 355-2	Depot Inspection Standard for Refinishing Repaired Signal Equipment.
TB SIG 355-3	Depot Inspection Standard for Moisture and Fungus Resistant Treatment.
TB 746-10	Field Instructions for Painting and Preserving Electronics Command Equipment.
TM 55-1500-323-25	Organizational, Direct Support, General Support and Depot Maintenance Manual: Installation Practices for Aircraft Electric and Electronic Wiring.
TM 38-750	The Army Maintenance Management System (TAMS).
TM 55-1500-204-25/1	General Aircraft Maintenance Manual.

**A-3.**

The following publications are available to the Direct Support and General Support repairman for the units included in the electronic configuration of the OH-58A helicopter

TM 11-6605-202-35	Direct Support, General Support, and Depot Maintenance Manual: Gyromagnetic Compass Set AN/ASN-43.
SC 5180-91-CL-S21	Sets, Kits and Outfits Components List: Tool Kit, Electronic Equipment, TK 100/G. (FSN 5180-605-0079)
TM 11-5895-490-35	Intermediate and Direct/General Support Maintenance With Depot Overhaul Instructions: Receiver-Transmitter, Radio RT-859/APX-72, RT-859A/APX-72 and Mountings MT-3809/APX-72, MT-3948/APX-72 (Bendix Communications Division). (NAVAIR-16-30APX72-2; NAVSHIPS 0967-217-4020; TO 12P4-2APX72-2).
TM 11-5826-227-34	Direct Support, and General Support Maintenance Manual: Direction Finder Set AN/ARN-89 and AN/ARN-89A.
TM 11-5821-262-35	Direct Support, General Support, and Depot Maintenance Manual: Control, Communication System C-6533/ARC.
TM 11-5841-283-20	Organizational Maintenance Manual: Detecting Set, Radar Signal AN/APR-39 (V)1 (NSN 5841-01-023-7112).
(C)TM 11-5841-283-34	Direct Support and General Support Maintenance Manual: Detecting Set, Radar Signal AN/APR-39 (V)1(U) (NSN 5841-01-023-7112). (U)
TM 11-6625-366-15	Operator's Organizational, Direct Support, General Support and Depot Maintenance Manual, Multimeter TS-352 B/U.

## INDEX

	Paragraph	Page
Adf Signals .....	2-14	2-11
Alignment Procedures .....	3-21	3-14
Assembly, ATS .....	5-11	5-8
Automatic Direction Finder Facility Alignment .....	3-23	3-16
Audio Threshold System (ATS) .....	5-2	5-1
Capacitor Board .....	2-21	2-14
Capacitor Board .....	4-6	4-1
Cleaning, ATS .....	5-9	5-6
Compass Facility Alignment .....	3-22	3-14
Copilot's Audio .....	2-7	2-6
Copilot's Microphone Keying Circuit .....	2-10	2-10
Crewman's Audio .....	2-6	2-7
Crew's Microphone Keying Circuit .....	2-11	2-10
Disassembly, ATS .....	5-8	5-6
General Instructions .....	3-1	3-1
General Instructions.....	5-1	5-1
Gyromagnetic Compass Set.....	2-15	2-11
Homing Compass Set .....	2-13	2-10
IFF System (AN/APX-72)..	4-8	4-2
Impedance-Matching Network .....	2-19	2-14
Impedance-Matching Network .....	4-3	4-1
Index of Publications .....	1-2	1-1
Inspection, ATS .....	5-10	5-7
No. 2 FM Antenna .....	4-5	4-1
Organization of Troubleshooting Procedures .....	3-2	3-1
Parts Replacement .....	3-20	3-10
Pilot's Audio .....	2-6	2-4
Pilot's Microphone Keying Circuit .....	2-9	2-7
Primary Power Application .....	2-2	2-1
Proximity Warning Facility Installation .....	1-5	1-4
Receive Audio .....	2-3	2-3
Reference Designations .....	1-4	1-1
Removal and Replacement of Cables and Wiring .....	3-18	3-6
Removal and Replacement of Circuit Breakers .....	3-19	3-10
Reporting Equipment Improvement Recommendations (EIR) .....	1-3.1	
Reporting of Errors .....	1-3	
RfReceive-Transmit Signals.....	2-12	2-10
Radar Warning System Installation .....	1-5.1	
Radar Warning System.....	2-16.1	

	Paragraph	Page
Scope of Manual . . . . .	1-1	1-1
Static Inverter . . . . .	2-18	2-14
Static Inverter . . . . .	4-7	4-1
Storage Battery . . . . .	2-20	7-14
Terminal Board Resistance Measurements . . . . .	3-16	3-8
Terminal Board Voltage Measurements . . . . .	3-15	3-6
Test Equipment . . . . .	4-2	4-1
Teat Equipment, ATS. ....	5-3	5-1
Test Equipment, Tools, and Materials Required . . . . .	3-3	3-2
Test Procedures, ATS Audio Section . . . . .	5-4	5-1
Test Procedures, ATS Control Section . . . . .	5-5	5-2
Test Setup . . . . .	3-5	3-3
Transmit Audio . . . . .	2-4	2-5
Transponder . . . . .	2-16	2-11
Troubleshooting the ATS Audio Section” . . . . .	5-6	5-4
Troubleshooting the ATS Control Section . . . . .	5-7	5-4
Troubleshootingthe Automatic Direction Finder . . . . .	3-11	3-4
Troubleshooting the VHF Command Facility . . . . .	3-10	3-4
Troubkshooting the Gyromagnetic Compass Set . . . . .	3-13	3-5
Troubleshooting the Liaison Facility . . . . .	3-7	3-3
Troubleshooting the Intercommunication and Audio Facility . . . . .	3-6	3-3
Troubleshooting the ProximityWaming Facility (YG-1054) . . . . .	3-12	3-5
Troubleshooting the Transponder . . . . .	3-14	3-6
Troubleshooting the UHF Command Facility (AN/ARC-116) . . . . .	3-8	3-4
Troubleshooting the UHF Command Facility (AN/ARC-51BX).. . . . .	3-9	3-4
Use of Term Hertz . . . . .	1-6	1-4
Vhf/Fm Antenna . . . . .	4-4	4-1

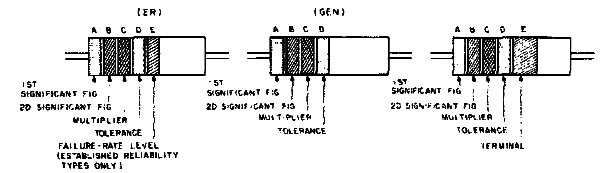

COLOR CODE MARKING FOR COMPOSITION TYPE RESISTORS. COLOR CODE MARKING FOR FILM TYPE RESISTORS.

TABLE 1  
COLOR CODE FOR COMPOSITION TYPE AND FILM TYPE RESISTORS.

BAND A		BAND B		BAND C		BAND D		BAND E	
COLOR	FIRST SIGNIFICANT FIGURE	COLOR	SECOND SIGNIFICANT FIGURE	COLOR	MULTIPLIER	COLOR	RESISTANCE TOLERANCE (PERCENT)	COLOR	FAILURE RATE LEVEL
BLACK	0	BROWN	1	BLACK	10	BROWN	M1-D	BROWN	M1-D
BROWN	1	BROWN	2	RED	100	RED	P-D1	RED	P-D1
RED	2	RED	2	ORANGE	1,000	ORANGE	Y-D1	ORANGE	Y-D1
ORANGE	3	ORANGE	3	YELLOW	10,000	SILVER	±10 (COMP. TYPE ONLY)	YELLOW	S-C-D1
YELLOW	4	YELLOW	4	GREEN	100,000	GOLD	±5	WHITE	S-C-D2
GREEN	5	GREEN	5	BLUE	1,000,000	RED	±2 (NO APPLICABLE TO ESTABLISHED RELIABILITY)		
BLUE	6	BLUE	6						
PURPLE (VIOLET)	7	PURPLE (VIOLET)	7						
GRAY	8	GRAY	8	SILVER	0.1				
WHITE	9	WHITE	9	GOLD	0.1				

BAND A -- THE FIRST SIGNIFICANT FIGURE OF THE RESISTANCE VALUE (BANDS A THRU D SHALL BE OF EQUAL WIDTH)

BAND B -- THE SECOND SIGNIFICANT FIGURE OF THE RESISTANCE VALUE

BAND C -- THE MULTIPLIER (THE MULTIPLIER IS THE FACTOR BY WHICH THE TWO SIGNIFICANT FIGURES ARE MULTIPLIED TO YIELD THE NOMINAL RESISTANCE VALUE)

BAND D -- THE RESISTANCE TOLERANCE

BAND E -- WHEN USED ON COMPOSITION RESISTORS, BAND E INDICATES ESTABLISHED RELIABILITY FAILURE-RATE LEVEL (PERCENT FAILURE PER 1,000 HOURS) ON FILM RESISTORS THIS BAND SHALL BE APPROXIMATELY 1/10 THIRDS THE WIDTH OF OTHER BANDS, AND INDICATES TYPE OF TERMINAL RESISTANCES (IDENTIFIED BY NUMBERS AND LETTERS (THESE ARE NOT COLOR CODED))

SOME RESISTORS ARE IDENTIFIED BY THREE OR FOUR DIGIT ALPHA NUMERIC DESIGNATORS. THE LETTER R IS USED IN PLACE OF A DECIMAL POINT WHEN (NOMINAL) VALUES OF AN OHM ARE EXPRESSED. FOR EXAMPLE:

2R7 = 2.7 OHMS 10R0 = 10.0 OHMS

FOR WIRE-WOUND TYPE RESISTORS COLOR CODING IS NOT USED. IDENTIFICATION MARKING IS SPECIFIED IN EACH OF THE APPLICABLE SPECIFICATIONS

EXAMPLES OF COLOR CODING

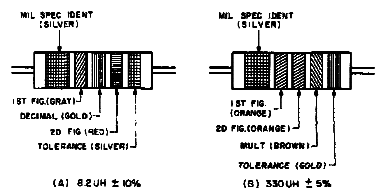
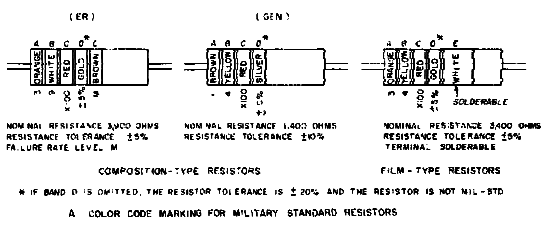

COLOR CODING FOR TUBULAR ENCAPSULATED R.F. CHOKES. AT A, AN EXAMPLE OF THE CODING FOR AN 8.2UH CHOKER IS GIVEN. AT B, THE COLOR BANDS FOR A 330UH INDUCTOR ARE ILLUSTRATED.

TABLE 2  
COLOR CODING FOR TUBULAR ENCAPSULATED R.F. CHOKES.

COLOR	SIGNIFICANT FIGURE	MULTIPLIER	INDUCTANCE TOLERANCE (PERCENT)
BLACK	0	1	
BROWN	1	10	1
RED	2	100	2
ORANGE	3	1,000	3
YELLOW	4		
GREEN	5		
BLUE	6		
VIOLET	7		
GRAY	8		
WHITE	9		
NONE		80	
SILVER		10	
GOLD	DECIMAL POINT	5	

MULTIPLIER IS THE FACTOR BY WHICH THE TWO COLOR FIGURES ARE MULTIPLIED TO OBTAIN THE INDUCTANCE VALUE OF THE CHOKER COIL.

CAPACITORS, FIXED, VARIOUS-DIELECTRICS, STYLES CM, CN, CY, AND CB.

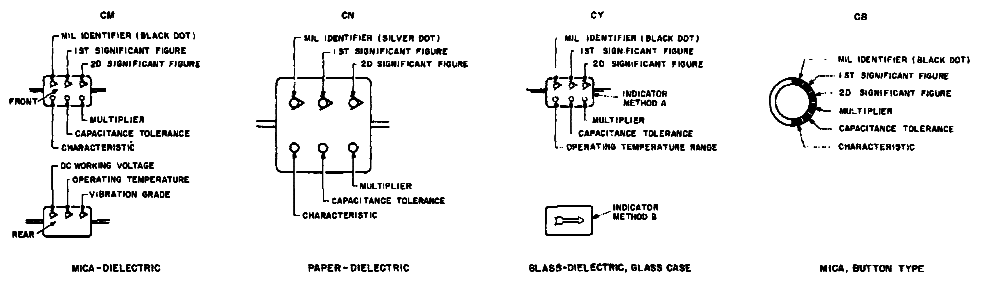

TABLE 3 -- FOR USE WITH STYLES CM, CN, CY AND CB.

COLOR	MIL ID	1ST SIG FIG.	2D SIG FIG.	MULTIPLIER	CAPACITANCE TOLERANCE	CHARACTERISTICS	DC WORKING VOLTAGE	OPERATING TEMPERATURE RANGE	VIBRATION GRADE
BLACK	CM, CN, CY, CB	0	0	1	±20%	±20%	A	-55° to +70°C	10-55 Hz
BROWN		1	1	10			B		
RED		2	2	100	±2%	±2%	C	-55° to +85°C	
ORANGE		3	3	1,000	±50%		D	300	
YELLOW		4	4	0.000			E	-55° to +125°C	10-2,000 Hz
GREEN		5	5		±5%		F	500	
BLUE		6	6					-55° to +100°C	
PURPLE (VIOLET)		7	7						
GRAY		8	8						
WHITE		9	9						
GOLD				0.1	±5%	±5%			
SILVER	CN			0.01	±10%	±10%			

TABLE 4 -- TEMPERATURE COMPENSATING, STYLE CC.

COLOR	TEMPERATURE COEFFICIENT <sup>1</sup>	1ST SIG FIG.	2D SIG FIG.	MULTIPLIER	CAPACITANCE TOLERANCE OVER 10 UUF	CAPACITANCE TOLERANCE 10 UUF OR LESS	MIL ID
BLACK	0	0	0	1		±2.0 UUF	CC
BROWN	-30	1	1	10	±1%		
RED	-80	2	2	100	±2%	±0.25 UUF	
ORANGE	-100	3	3	1,000			
YELLOW	-200	4	4				
GREEN	-350	5	5		±5%	±0.5 UUF	
BLUE	-470	6	6				
PURPLE (VIOLET)	-750	7	7				
GRAY		8	8	0.1 <sup>2</sup>			
WHITE		9	9	0.1 <sup>2</sup>	±10%		
GOLD	+100			0.1		±1.0 UUF	
SILVER				0.01			

1. THE MULTIPLIER IS THE NUMBER BY WHICH THE TWO SIGNIFICANT (SIG) FIGURES ARE MULTIPLIED TO OBTAIN THE CAPACITANCE IN UUF.

2. LETTERS INDICATE THE CHARACTERISTICS DESIGNATED IN APPLICABLE SPECIFICATIONS: MIL-C-5, MIL-C-250, MIL-C-11272B, AND MIL-C-10950C RESPECTIVELY.

3. LETTERS INDICATE THE TEMPERATURE RANGE AND VOLTAGE-TEMPERATURE LIMITS DESIGNATED IN MIL-C-11015D.

4. TEMPERATURE COEFFICIENT IN PARTS PER MILLION PER DEGREE CENTIGRADE.

5. OPTIONAL CODING WHERE METALLIC PIGMENTS ARE UNDESIRABLE.

C. COLOR CODE MARKING FOR MILITARY STANDARD CAPACITORS.

Figure FO-1. Color code for resistors, inductors, and capacitors.

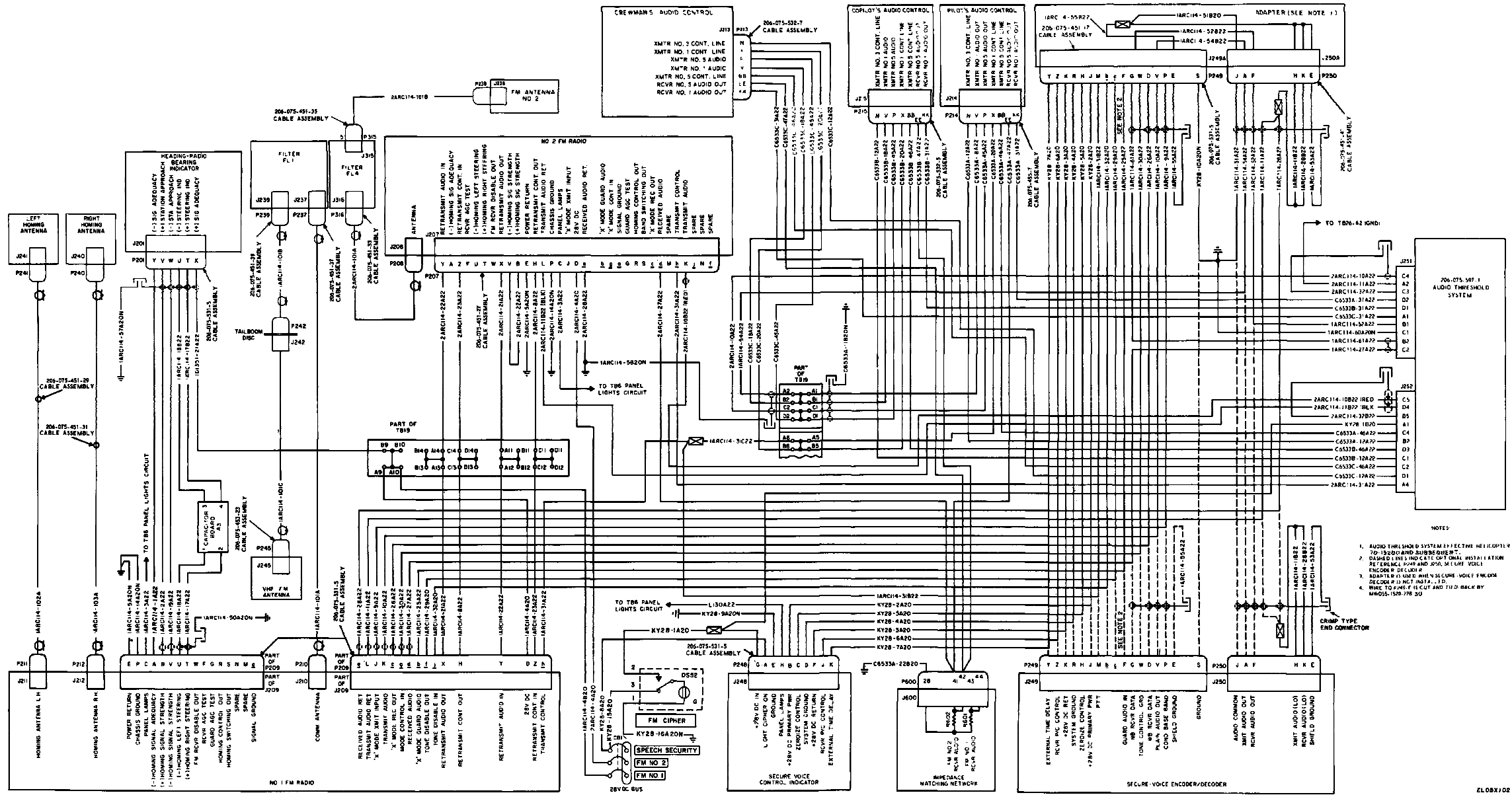

- NOTES:
1. AUDIO THREE-SHIELD SYSTEM IS EFFECTIVE HELICOPTER'S N 70-1532 AND SUBSEQUENT.
  2. DASHED LINES INDICATE OPTIONAL INSTALLATION. REFER TO 206-075-597-1 (REF. 1001) ENCODER DECODER.
  3. ADAPTER IS USED WITH SYSTEMS HAVING FM CONTROL DECODER IS NOT INSTALLED.
  4. WIRE TO 206-075-531-5 CUT AND TIED BACK BY WMOOS-150-708-30.

Figure FO-2. Liaison facility interunit schematic diagram.

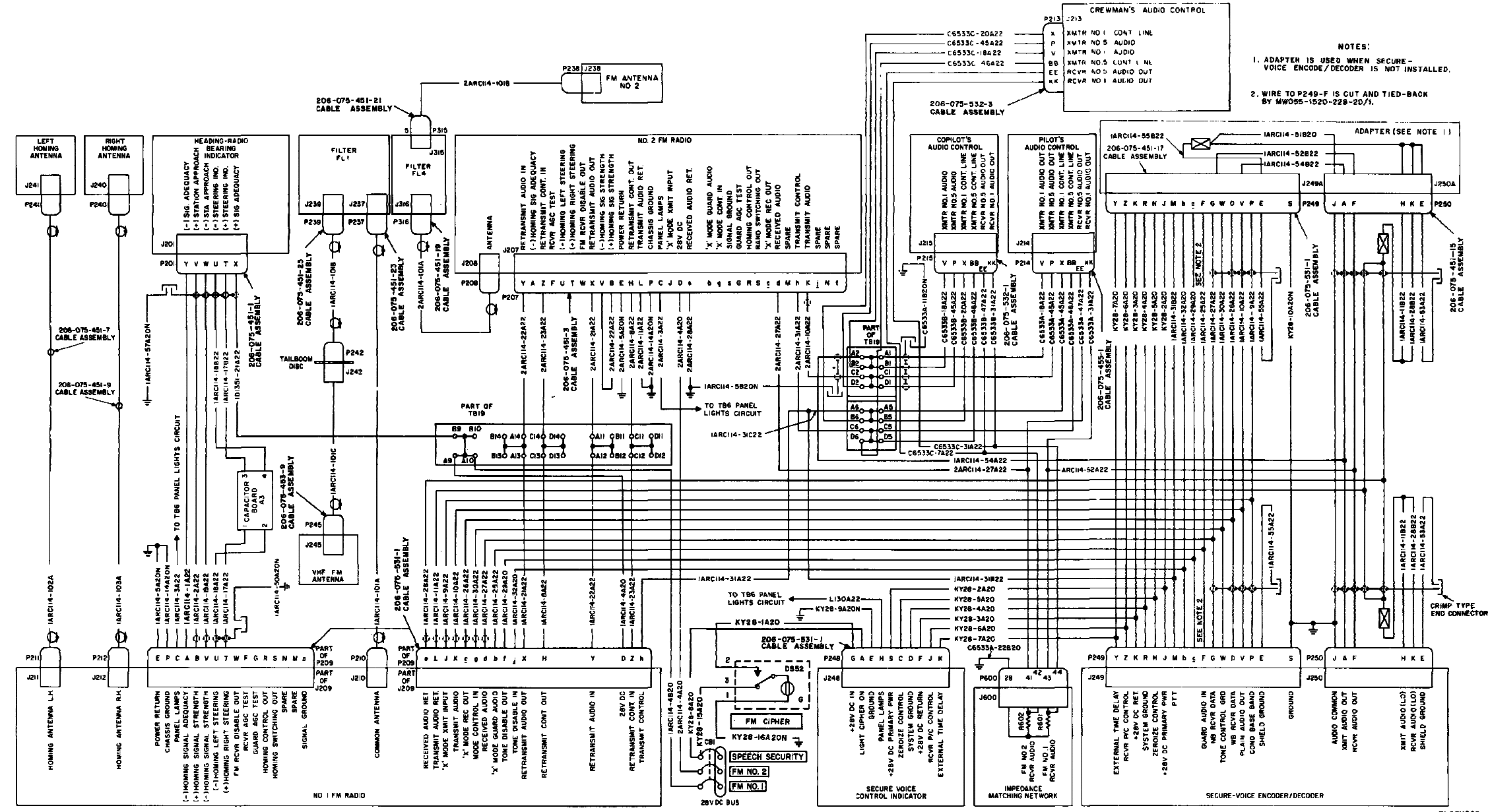

NOTES:  
 1. ADAPTER IS USED WHEN SECURE-VOICE ENCODE/DECODE IS NOT INSTALLED.  
 2. WIRE TO P249-F IS CUT AND TIED-BACK BY MW05-1520-228-2D/1.

Figure FO-3. Liason facility interunit schematic diagram without audio threshold system.

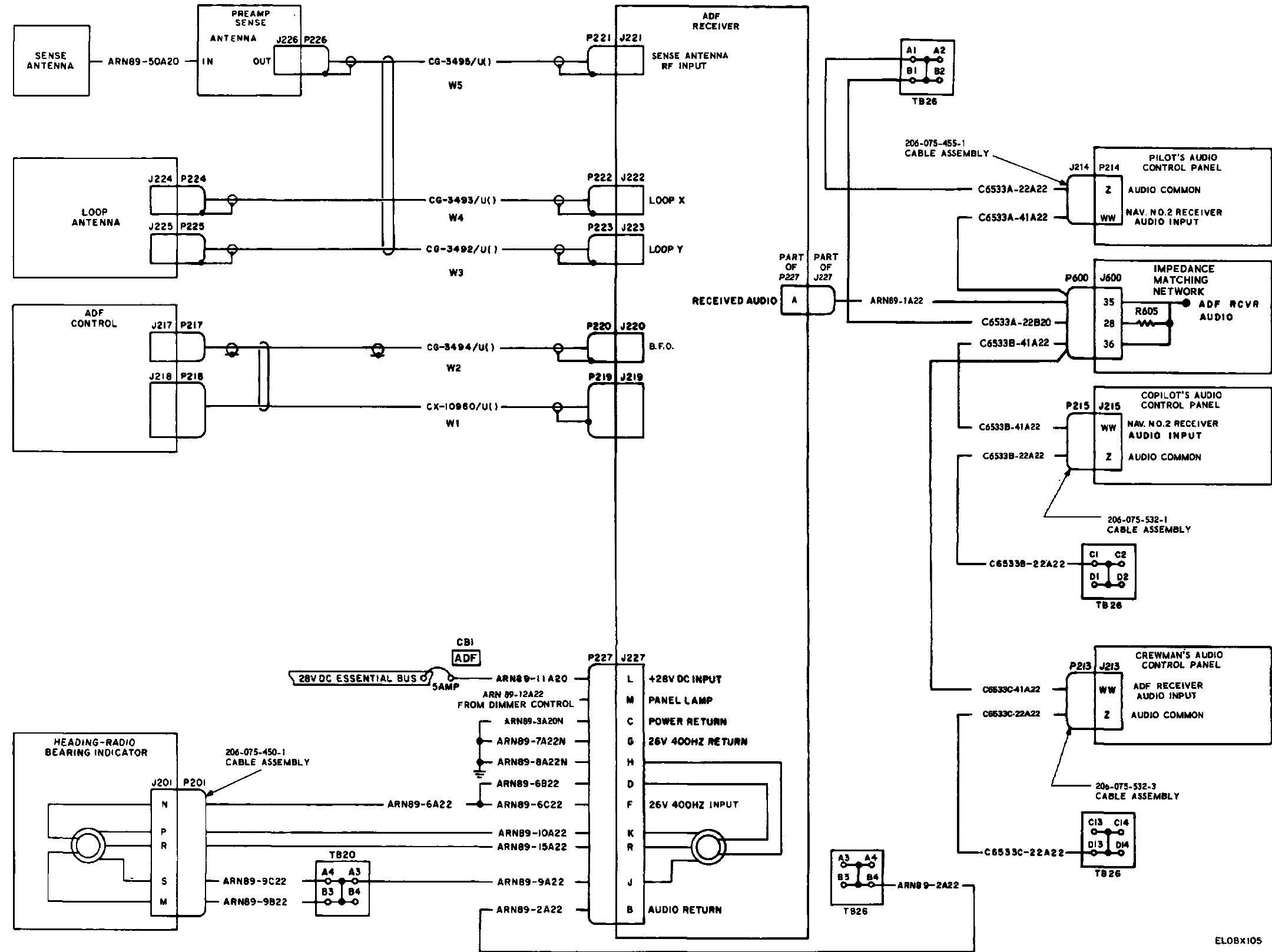

Figure FO-4. Automatic direction finder facility interunit schematic diagram.



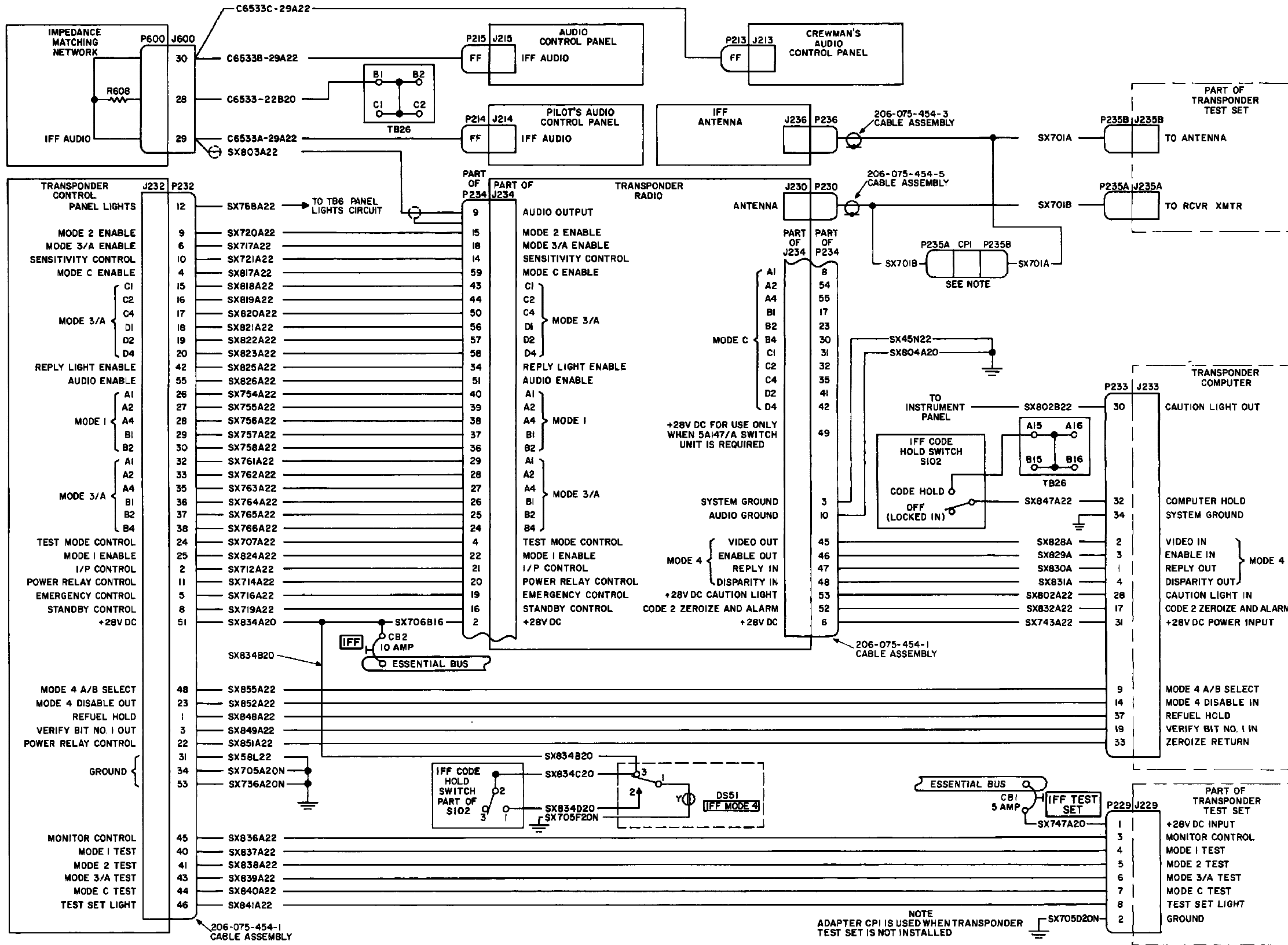

Figure FO-5. Identification facility interunit schematic diagram.

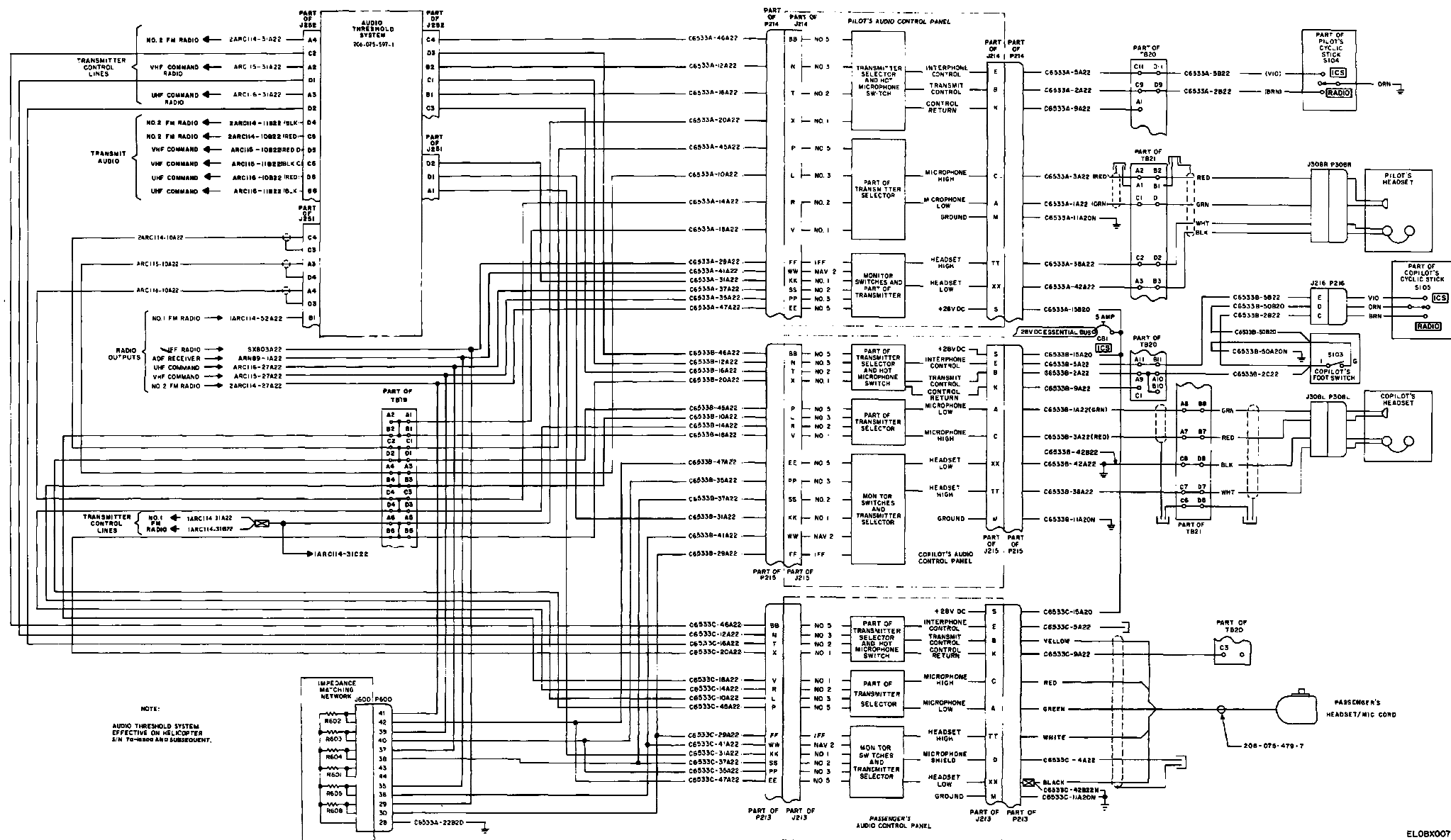

Figure FO-6. Intercom and audio facility interunit schematic diagram.

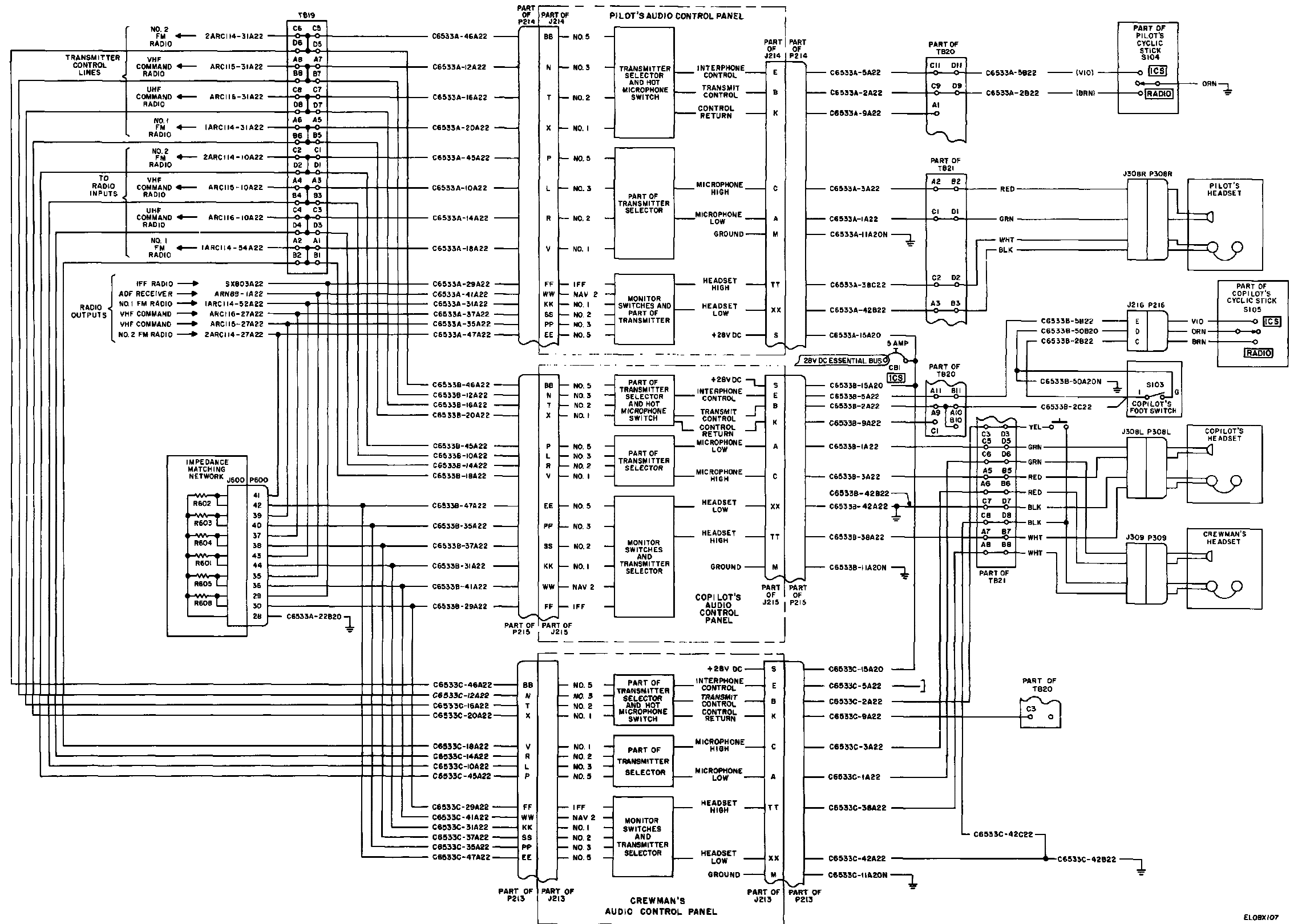
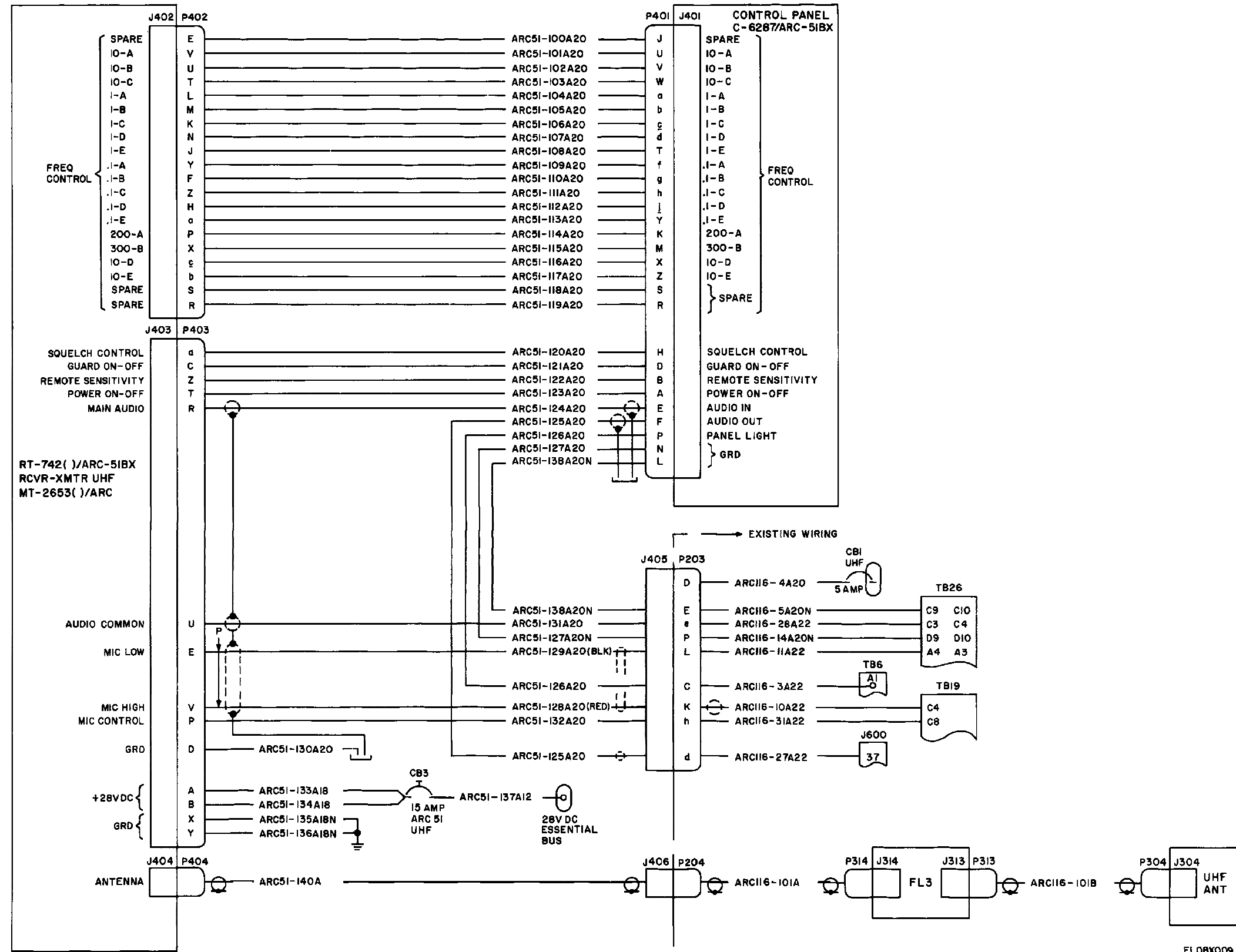

Figure FO-7. Intercom and audio facility interunit schematic diagram without audio threshold system.



ELOBX009

Figure FO-8. Uhf command facility interunit schematic diagram (AN/ARC-51BX).

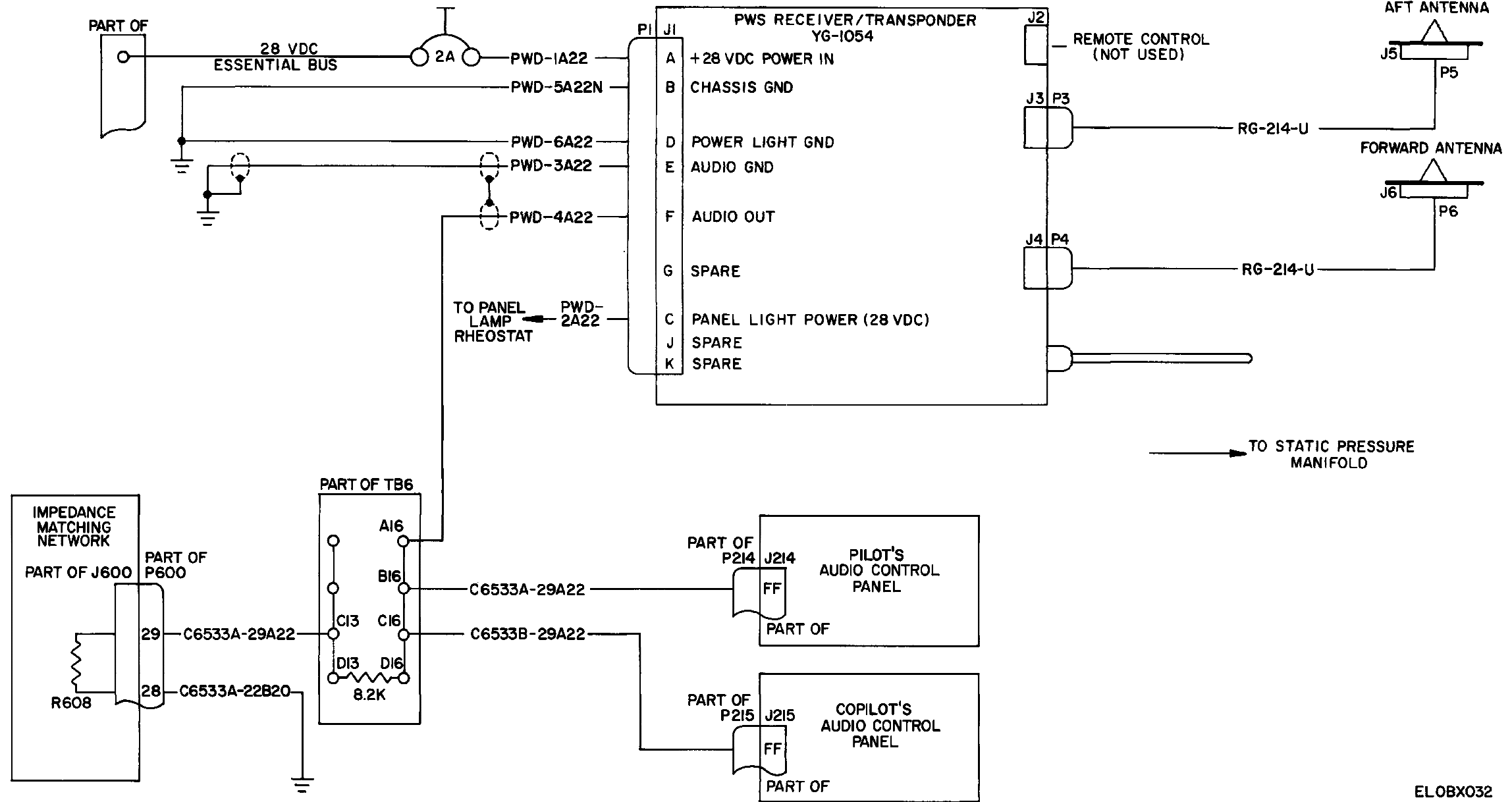

Figure FO-9. Proximity warning facility interunit schematic diagram.

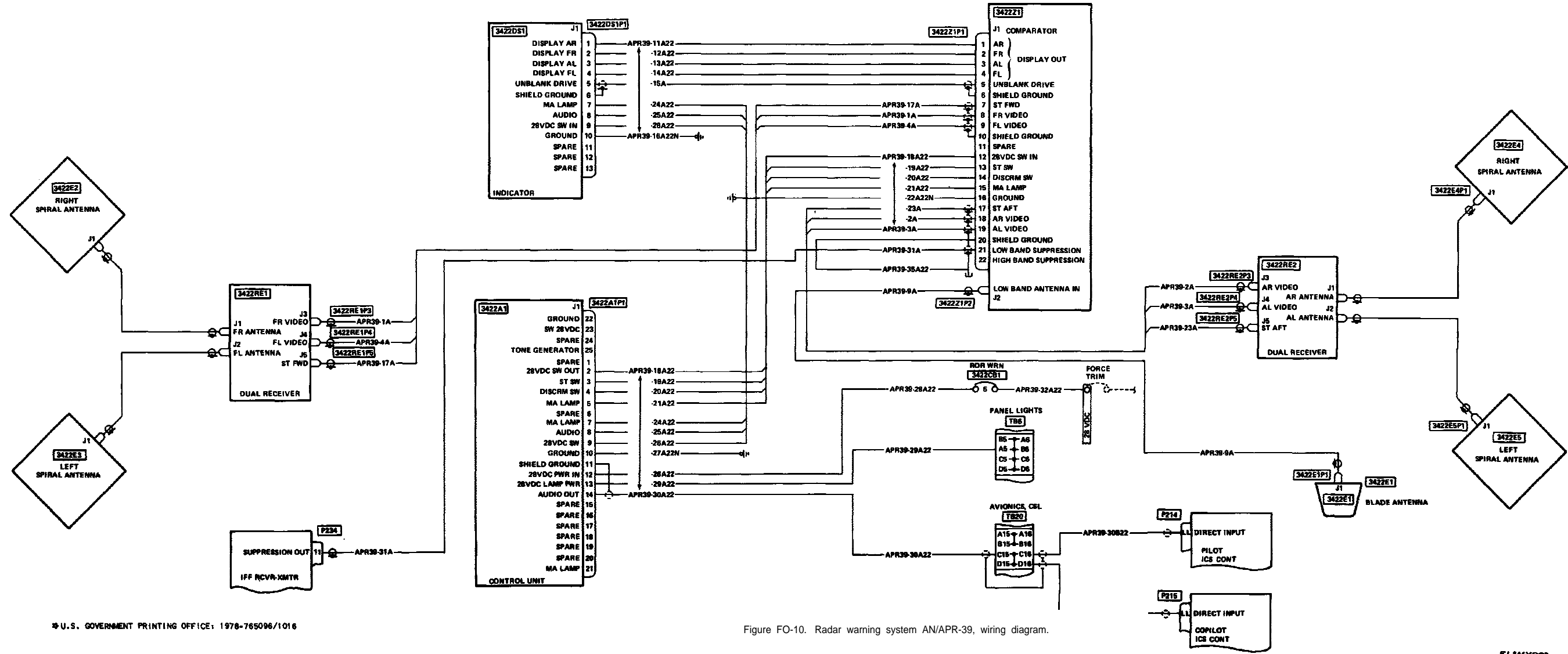

Figure FO-10. Radar warning system AN/APR-39, wiring diagram.

By Order of the Secretary of the Army:

FRED C. WEYAND  
*General, United States Army*  
*Chief of Staff*

Official:

PAUL T. SMITH  
*Major General, United States Army*  
*The Adjutant General*

Distribution:

To be distributed in accordance with DA Form 12-31 (qty rqr block no. 603), Direct/General Support 11 -series TM literature requirements for OH-58 aircraft.

RECOMMENDED CHANGES TO EQUIPMENT TECHNICAL MANUALS



SOMETHING WRONG WITH THIS MANUAL?

THEN...JOT DOWN THE DOPE ABOUT IT ON THIS FORM, TEAR IT OUT, FOLD IT AND DROP IT IN THE MAIL!

FROM: (YOUR UNIT'S COMPLETE ADDRESS)

Commander  
Stateside Army Depot  
ATTN: AMSTA-US  
Stateside, N.J. 07703

DATE 10 July 1975

PUBLICATION NUMBER TM 11-5840-340-12	DATE 23 Jan 74	TITLE Radar Set AN/SPC-76
---	-------------------	------------------------------

BE EXACT...PIN-POINT WHERE IT IS				IN THIS SPACE TELL WHAT IS WRONG AND WHAT SHOULD BE DONE ABOUT IT:
PAGE NO.	PARA-GRAPH	FIGURE NO.	TABLE NO.	
2-25	2-28			<p>Recommend that the installation antenna alignment procedure be changed through to specify a 2° IFF antenna lag rather than 1°.</p> <p>REASON: Experience has shown that with only a 1° lag, the antenna servo system is too sensitive to wind gusting in excess of 20 knots, and has a tendency to rapidly accelerate and decelerate as it hunts, causing strain to the drive train. Hunting is minimized by adjusting the lag to 2° without degradation of operation.</p>
3-10	3-3		3-1	<p>Item 5, Function column. Change "2 db" to "3db."</p> <p>REASON: The adjustment procedure for the TRANS POWER FAULT indicator calls for a 3 db (500 watts) adjustment to light the TRANS POWER FAULT indicator.</p>
5-6	5-8			<p>Add new step f.1 to read, "Replace cover plate removed in step e.1, above."</p> <p>REASON: To replace the cover plate.</p>
		FO3		<p>Zone C 3. On J1-2, change "+24 VDC to "+5 VDC."</p> <p>REASON: This is the output line of the 5 VDC power supply. + 24 VDC is the input voltage.</p>

TEAR ALONG DOTTED LINE

TYPED NAME, GRADE OR TITLE, AND TELEPHONE NUMBER SSG I. M. DeSpirito 999-1776	SIGN HERE: <i>SSG I. M. DeSpirito</i>
--	--



RECOMMENDED CHANGES TO EQUIPMENT TECHNICAL PUBLICATIONS



THEN...JOT DOWN THE  
DOPE ABOUT IT ON THIS FORM.  
CAREFULLY TEAR IT OUT, FOLD IT  
AND DROP IT IN THE MAIL.

SOMETHING WRONG WITH PUBLICATION

FROM: (PRINT YOUR UNIT'S COMPLETE ADDRESS)

DATE SENT

PUBLICATION NUMBER

PUBLICATION DATE

PUBLICATION TITLE

BE EXACT PIN-POINT WHERE IT IS

PAGE  
NO.

PARA-  
GRAPH

FIGURE  
NO.

TABLE  
NO.

IN THIS SPACE, TELL WHAT IS WRONG  
AND WHAT SHOULD BE DONE ABOUT IT.

TEAR ALONG PERFORATED LINE

PRINTED NAME, GRADE OR TITLE AND TELEPHONE NUMBER

SIGN HERE

FILL IN YOUR  
UNIT'S ADDRESS

DEPARTMENT OF THE ARMY

\_\_\_\_\_  
\_\_\_\_\_

OFFICIAL BUSINESS  
PENALTY FOR PRIVATE USE \$300

FOLD BACK

POSTAGE AND FEES PAID  
DEPARTMENT OF THE ARMY  
DOD 314



Commander  
US Army Electronics Command  
ATTN: AMSEL-MA-Q  
Fort Monmouth, NJ 07703

CUT ALONG DOTTED LINE

FOLD BACK

# The Metric System and Equivalents

## Linear Measure

1 centimeter = 10 millimeters = .39 inch  
 1 decimeter = 10 centimeters = 3.94 inches  
 1 meter = 10 decimeters = 39.37 inches  
 1 dekameter = 10 meters = 32.8 feet  
 1 hectometer = 10 dekameters = 328.08 feet  
 1 kilometer = 10 hectometers = 3,280.8 feet

## Weights

1 centigram = 10 milligrams = .15 grain  
 1 decigram = 10 centigrams = 1.54 grains  
 1 gram = 10 decigrams = .035 ounce  
 1 dekagram = 10 grams = .35 ounce  
 1 hectogram = 10 dekagrams = 3.52 ounces  
 1 kilogram = 10 hectograms = 2.2 pounds  
 1 quintal = 100 kilograms = 220.46 pounds  
 1 metric ton = 10 quintals = 1.1 short tons

## Liquid Measure

1 centiliter = 10 milliliters = .34 fl. ounce  
 1 deciliter = 10 centiliters = 3.38 fl. ounces  
 1 liter = 10 deciliters = 33.81 fl. ounces  
 1 dekaliter = 10 liters = 2.64 gallons  
 1 hectoliter = 10 dekaliters = 26.42 gallons  
 1 kiloliter = 10 hectoliters = 264.18 gallons

## Square Measure

1 sq. centimeter = 100 sq. millimeters = .155 sq. inch  
 1 sq. decimeter = 100 sq. centimeters = 15.5 sq. inches  
 1 sq. meter (centare) = 100 sq. decimeters = 10.76 sq. feet  
 1 sq. dekameter (are) = 100 sq. meters = 1,076.4 sq. feet  
 1 sq. hectometer (hectare) = 100 sq. dekameters = 2.47 acres  
 1 sq. kilometer = 100 sq. hectometers = .386 sq. mile

## Cubic Measure

1 cu. centimeter = 1000 cu. millimeters = .06 cu. inch  
 1 cu. decimeter = 1000 cu. centimeters = 61.02 cu. inches  
 1 cu. meter = 1000 cu. decimeters = 35.31 cu. feet

## Approximate Conversion Factors

To change	To	Multiply by	To change	To	Multiply by
inches	centimeters	2.540	ounce-inches	newton-meters	.007062
feet	meters	.305	centimeters	inches	.394
yards	meters	.914	meters	feet	3.280
miles	kilometers	1.609	meters	yards	1.094
square inches	square centimeters	6.451	kilometers	miles	.621
square feet	square meters	.093	square centimeters	square inches	.155
square yards	square meters	.836	square meters	square feet	10.764
square miles	square kilometers	2.590	square meters	square yards	1.196
acres	square hectometers	.405	square kilometers	square miles	.386
cubic feet	cubic meters	.028	square hectometers	acres	2.471
cubic yards	cubic meters	.765	cubic meters	cubic feet	35.315
fluid ounces	milliliters	29.573	cubic meters	cubic yards	1.308
pints	liters	.473	milliliters	fluid ounces	.034
quarts	liters	.946	liters	pints	2.113
gallons	liters	3.785	liters	quarts	1.057
ounces	grams	28.349	liters	gallons	.264
pounds	kilograms	.454	grams	ounces	.035
short tons	metric tons	.907	kilograms	pounds	2.205
pound-feet	newton-meters	1.356	metric tons	short tons	1.102
pound-inches	newton-meters	.11296			

## Temperature (Exact)

°F Fahrenheit temperature      5/9 (after subtracting 32)      Celsius temperature      °C

**PIN: 028850**